

GENERAL SPECIFICATIONS

Valbia manufactures rack and pinion pneumatic actuators, available in spring return or double acting version, with 0°-90° standard rotation or 0°-180°, and are standardly furnished with FKM VITON® seals. Valbia offers a product with a unique patented design, which is able to guarantee high quality standard, performance and reliability.

Valbia actuators are versatile and suitable to different applications and operating conditions.

Bonomi North America also provides a wide range of accessories such as solenoid valves, limit switches, positioners, and manual overrides.

Valbia pneumatic actuators are available in three versions:

- the 82 series: aluminum with 0°-90° rotation;
- the 83 series: aluminum with 0°-180° rotation;
- the 84 series: stainless steel with 0°-90° rotation.

In addition, Valbia offers a wide range of special versions designed to provide specific solutions for severe applications.

82 SERIES PNEUMATIC ACTUATORS

The 82 series, with an extruded and hard anodized aluminum body, is manufactured in 15 models to guarantee a wide range of choice according to the requested torque; it allows a 0°-90° rotation and is available in the spring return (SR) or double acting (DA) versions.

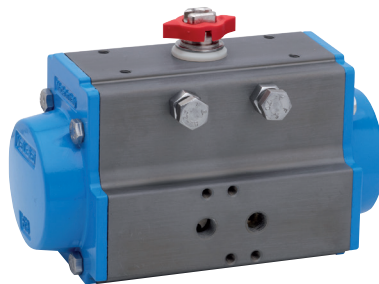

83 SERIES PNEUMATIC ACTUATORS

Available only in the double acting version, the 83 series is manufactured in 9 models according to the different torque output required. These actuators can provide a 0°-180° rotation with the possibility to adjust the run of the pistons by using the cam adjustment and the bolts mounted on the end caps.



84 SERIES PNEUMATIC ACTUATORS

The 84 series presents the same compact design and the same technical features of the 82 series, with the exception of construction material; The 84 series of Valbia is, in fact, manufactured using body, caps and pinion in stainless steel (A351 CF8M) and it is available in 5 models.

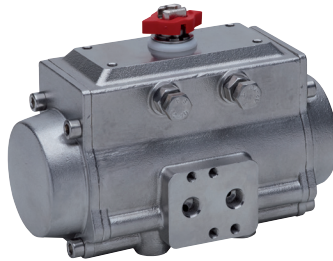

High temperature as standard: to withstand temperatures up to 302°F.

Low temperature option: for applications that require the use down to -40°F.

With 303 stainless steel pinion.

P.T.F.E. coating: coating applied over the entire actuator surface and cured in the oven. It provides excellent corrosion protection in a wide range of applications, involving chemical wash-downs.



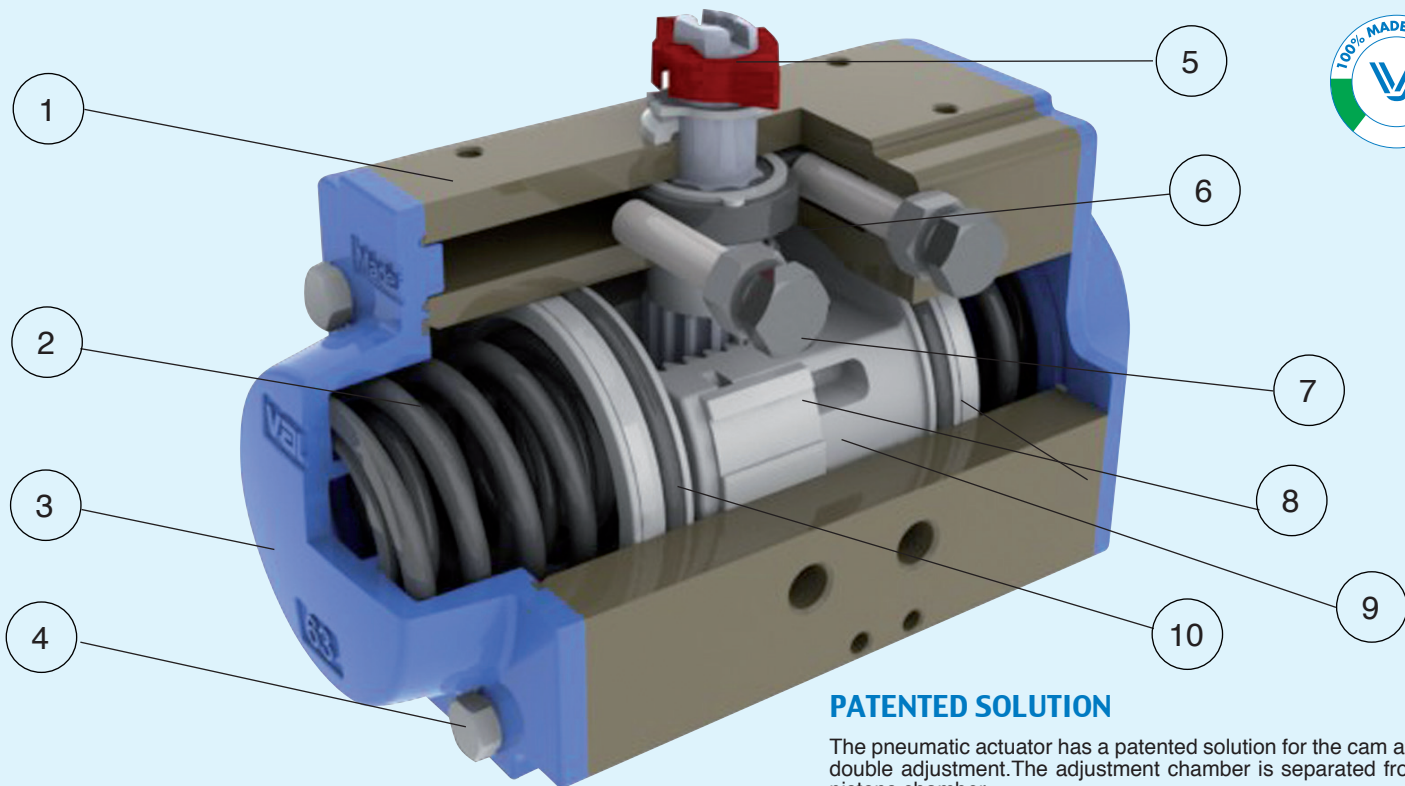

PATENTED SOLUTION

The pneumatic actuator has a patented solution for the cam and the double adjustment. The adjustment chamber is separated from the pistons chamber. This reduces the number of possible leak paths of the air cylinder, and allowing performances and longer term reliability of the actuator.

STANDARD VITON SEALS

- 1 **HARD ANODIZED EXTRUDED ALUMINIUM BODY:**
 - Hard anodized SURFACE finish (45-50 micron).
 - Excellent wear resistance.
 - High corrosion resistance.
 - Special surface finishing or coating for corrosive environments upon request.
 - High quality bore lapping to ensure low friction and long life.
- 2 **CONCENTRIC SPRING SETS**
 - Paint coating.
 - High resistance and reliability.
 - Spring sets to suit different air pressure/torque requirements.
 - Long end cap screws to allow safe dismantling for maintenance.
 - Same body dimensions for DA/SR versions.
- 3 **DIE CAST ALUMINUM END CAPS:**
 - Polyester powder coated.
 - Special coating for corrosive environments upon request.
- 4 **ASSEMBLING SCREW:**
 - Stainless steel.

STANDARDS CONNECTION:

- Top of pinion according to Namur standards.
- Solenoid valve connection according to Namur standards.
- Bottom according to ISO 5211-DIN 3337 patterns.

NOMINAL VALUES:

- Max. air pressure rating: 120 psi.
- Working temperature: standard (-4°F;+302°F), low (-40°F;+185°F).
- No lubrication maintenance required for the entire actuator lifetime.
- 100% factory tested.

ROTATION OPTION

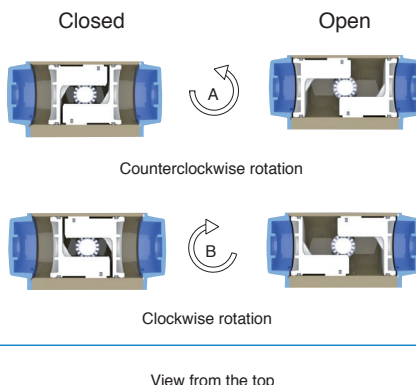

- 5 **SOLID STEEL BARSTOCK PINION (NOT CASTING):**
 - Nickel-plating to prevent internal and external corrosion for standard version.
 - Stainless steel for corrosive environments upon request.
 - Anti-blowout design.
- 6 **0°-90° ROTATION ADJUSTMENT CAM:**
 - Stainless steel.
 - ± 5° Adjustment for open and close position.
- 7 **0-90° ADJUSTMENT BOLTS:**
 - Stainless steel.
- 8 **POM PISTON GUIDES:**
 - Large contact area.
 - Low friction thanks to lubricating material.
 - Long life.
- 9 **DIE CAST ALUMINIUM PISTONS:**
 - Chemical nickel plating upon request.
- 10 **SEALS:**
 - Standard FKM FKM (Viton®).
 - Silicone low temperature version.

ANTI-BLOWOUT SYSTEM

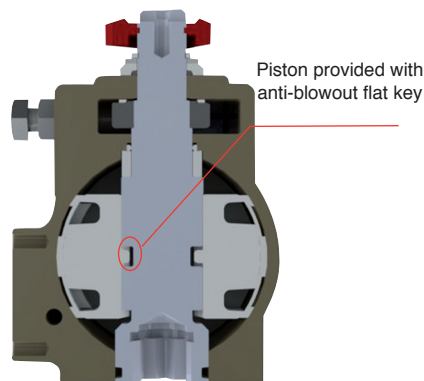

TWIN RACK AND PINION DESIGN:

- Consistent torque output.
- Compact design.
- Balanced internal forces.
- Robust design to ensure long life.

MOD. 32

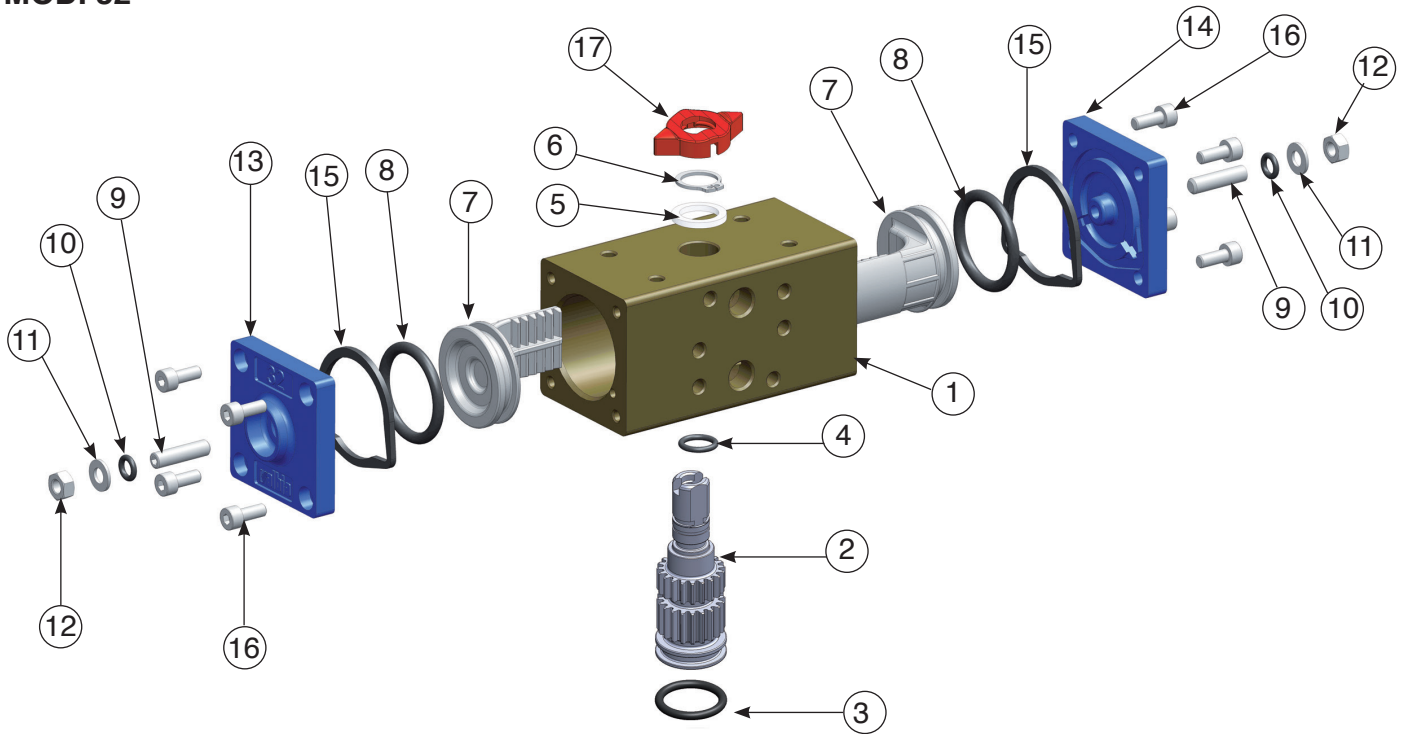

ITEM	DESCRIPTION	MATERIAL	TREATMENT	Q.TY
1	Body	Extruded aluminum	Hard anodized	1
2	Anti-blowout pinion	Steel	Nickel plated	1
• 3	O-ring	FKM (Viton®)		1
• 4	O-ring	FKM (Viton®)		1
• 5	Spacer ring	POM		1
6	Snap ring	Steel	Nickel plated	1
7	Piston	Die cast aluminum		2
• 8	O-ring	FKM (Viton®)		2
9	Adjustment bolt	Stainless steel		2
• 10	O-ring	FKM (Viton®)		2
11	Washer	Stainless steel		2
12	Adjustment bolt retaining nut	Stainless steel		2
13	Left end cap	Die cast aluminum	Powder-coated	1
14	Right end cap	Die cast aluminum	Powder-coated	1
15	End cap seats	FKM (Viton®)		2
16	End cap fixing screw	Stainless steel		8
17	Position indicator	Thermoplastic rubber TPE		1

• Parts subject to wear.

MOD. FROM 52 TO 230

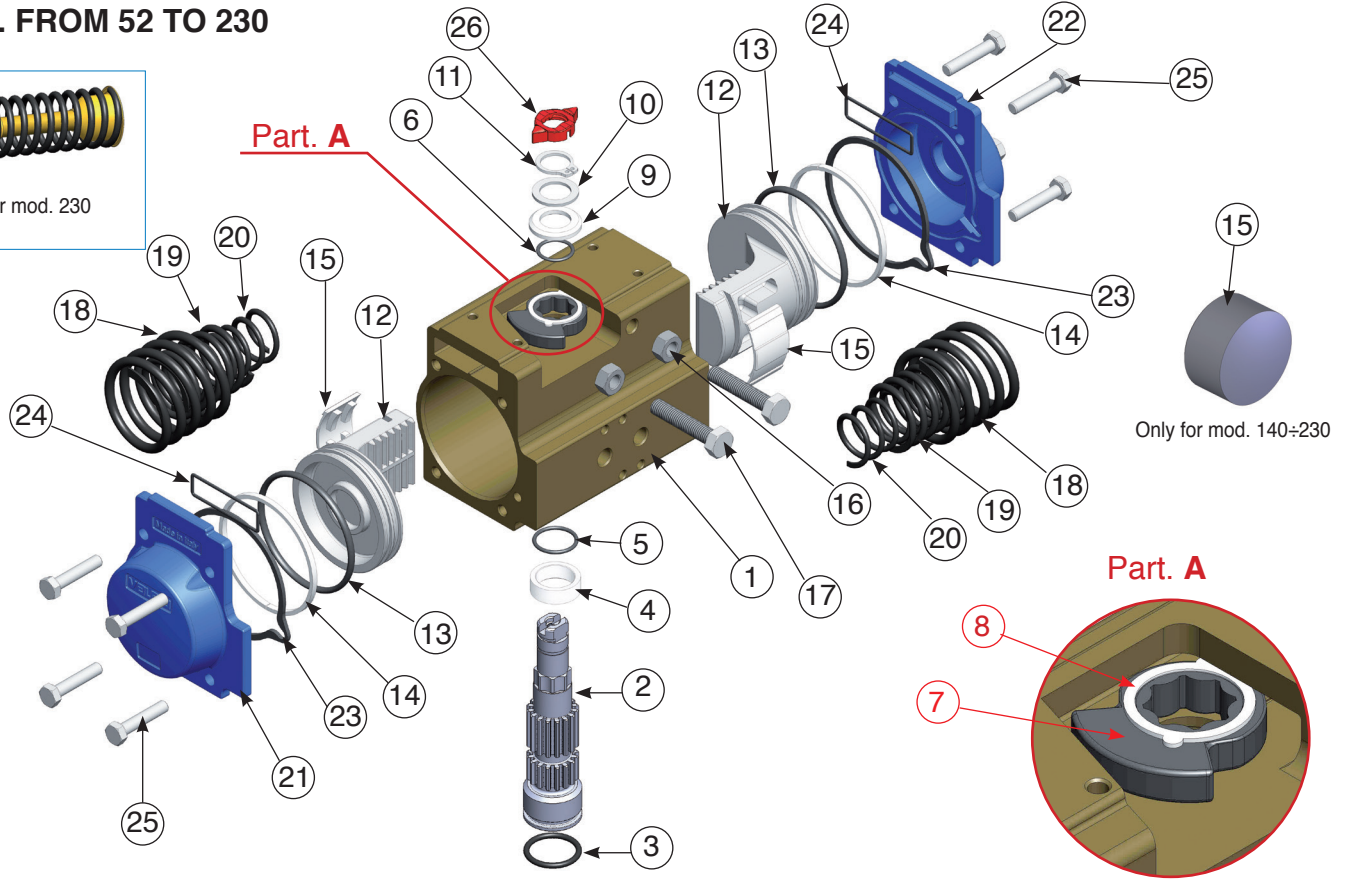

ITEM	DESCRIPTION	MATERIAL	TREATMENT	Q.TY DA	Q.TY SR
1	Body	Extruded aluminum	Hard anodized	1	1
2	Anti-blowout pinion	Steel	Nickel plated	1	1
• 3	O-ring	FKM (Viton®)		1	1
• 4	Spacer ring	POM		1	1
• 5	O-ring	FKM (Viton®)		1	1
• 6	O-ring	FKM (Viton®)		1	1
7	Cam	Stainless steel		1	1
8	Spacer	POM		1	1
• 9	Spacer	POM		1	1
10	Washer	Stainless steel		1	1
** 11	Snap ring	Steel	Nickel plated	1	1
12	Piston	Die cast aluminum		2	2
• 13	O-ring	FKM (Viton®)		2	2
• 14	Anti-friction ring	POM		2	2
• 15	Thrust block	POM		2 [4]	2 [4]
16	Adjustment bolt retaining nut	Stainless steel		2	2
17	Adjustment bolt	Stainless steel		2	2
18	External spring	Steel	Painted	0	See spring settings at page 143
*** 19	Central spring	Steel	Painted	0	
20	Internal spring	Steel	Painted	0	
21	Left end cap	Die cast aluminum	Powder-coated	1	1
22	Right end cap	Die cast aluminum	Powder-coated	1	1
23	End cap seats	FKM (Viton®)		2	2
24	O-ring	FKM (Viton®)		2	2
25	End cap screw	Stainless steel		8	8
26	Position indicator	Thermoplastic rubber TPE		1	1

• Parts subject to wear.
 (4) Valid for mod. 140-160-180-200-230 only.

** Reinforced series DIN 471 - UNI 7436.
 *** Only for mod. 160-180-200.

MOD. 270 - 330

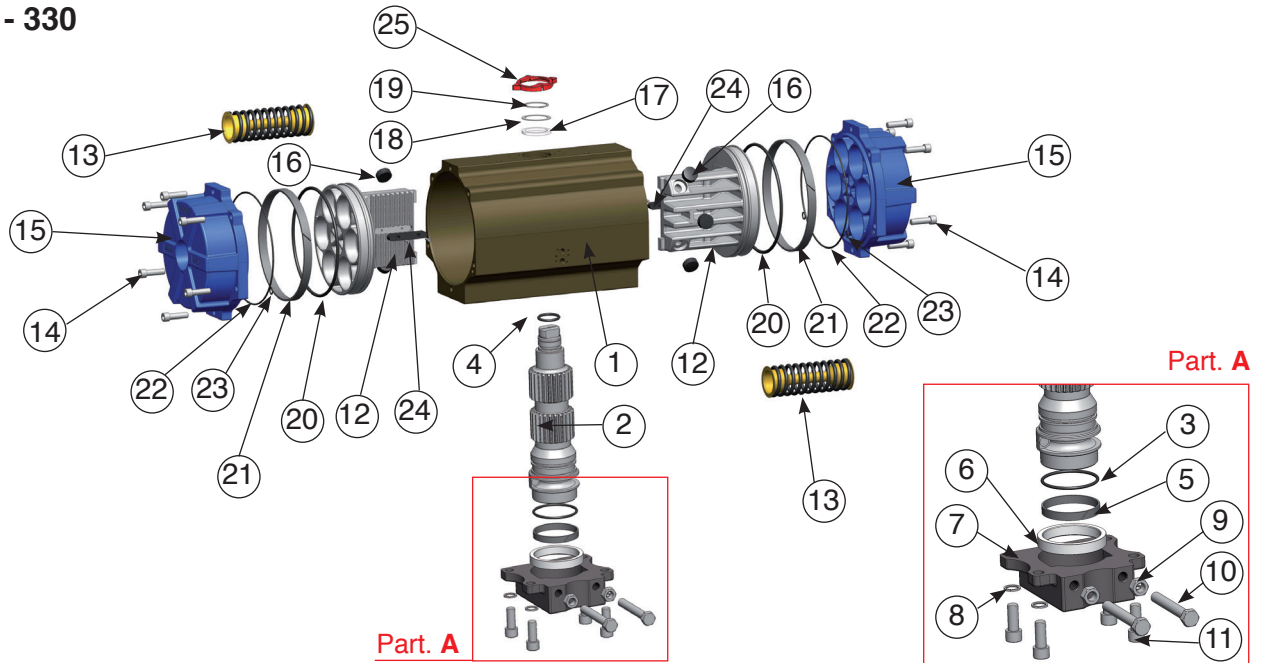

ITEM	DESCRIPTION	MATERIAL	TREATMENT	Q.TY DA	Q.TY SR
1	Body	Extruded aluminum	Hard anodized	1	1
2	Anti-blowout pinion	Steel	Nickel plated	1	1
• 3	O-ring	FKM (Viton®)		1	1
• 4	O-ring	FKM (Viton®)		1	1
• 5	Anti-friction ring	P.T.F.E 15% graphite		1	1
• 6	Anti-friction ring	P.T.F.E		1	1
7	Plate	mod.270 GGG40 - mod.330 C45	Painted	1	1
8	Washer	Stainless steel		4	8
9	Adjustment bolt retaining nut	Stainless steel		2	2
10	Adjustment bolt	Steel	Zinc plated	2	2
11	Screws	Stainless steel		4	4
12	Piston	Die cast aluminum		2	2
13	Precompressed spring	Steel	Painted	0	See spring settings at page 143
14	End cap screw	Stainless steel		mod.270 12 mod.330 16	mod.270 12 mod.330 16
15	End cap	Die cast aluminum	Powder-coated	2	2
• 16	Thrust block	POM		mod.270 6 mod.330 8	mod.270 6 mod.330 8
• 17	Spacer ring	POM		1	1
18	Pinion washer	Stainless steel		1	1
19	Snap ring	Steel	Nickel plated	1	1
• 20	O-ring	FKM (Viton®)		2	2
• 21	Anti-friction ring	P.T.F.E 15% graphite		2	2
22	O-ring	FKM (Viton®)		2	2
23	O-ring	FKM (Viton®)		mod.270 4 mod.330 2	mod.270 4 mod.330 2
24	Anti-blowout key	POM		2	2
25	Position indicator	Thermoplastic rubber TPE		1	1

• Parts subject to wear.

MOD. FROM 52 TO 100
STAINLESS STEEL ACTUATOR

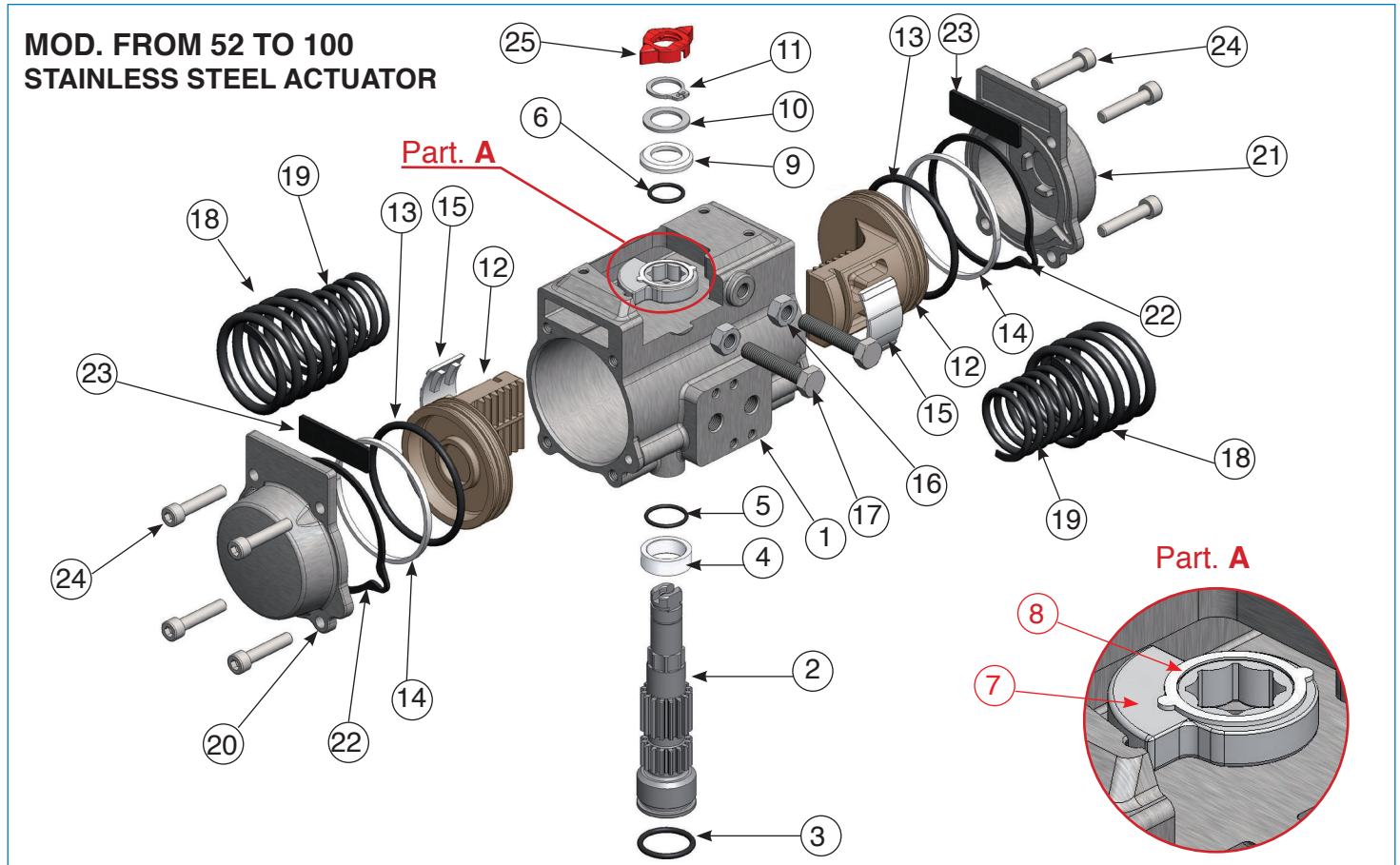

ITEM	DESCRIPTION	MATERIAL	TREATMENT	Q.TY DA	Q.TY SR
1	Body	Stainless steel		1	1
2	Anti-blowout pinion	Stainless steel		1	1
• 3	O-ring	FKM (Viton®)		1	1
• 4	Spacer ring	POM		1	1
• 5	O-ring	FKM (Viton®)		1	1
• 6	O-ring	FKM (Viton®)		1	1
7	Cam	Stainless steel		1	1
8	Spacer	POM		1	1
• 9	Spacer	POM		1	1
10	Washer	Stainless steel		1	1
11	Snap ring	Stainless steel		1	1
12	Piston	Die cast aluminum	Hard anodized	2	2
• 13	O-ring	FKM (Viton®)		2	2
• 14	Anti-friction ring	POM		2	2
• 15	Thrust block	POM		2	2
16	Adjustment bolt retaining nut	Stainless steel		2	2
17	Adjustment bolt	Stainless steel		2	2
18	External spring	Steel	Powder coating	0	See spring settings at page 143
19	Internal spring	Steel	Powder coating	0	
20	Left end cap	Stainless steel		1	1
21	Right end cap	Stainless steel		1	1
22	End cap seats	FKM (Viton®)		2	2
23	End cap seats	FKM (Viton®)		2	2
24	End cap screw	Stainless steel		8	8
25	Position indicator	Thermoplastic rubber TPE		1	1

• Parts subject to wear.

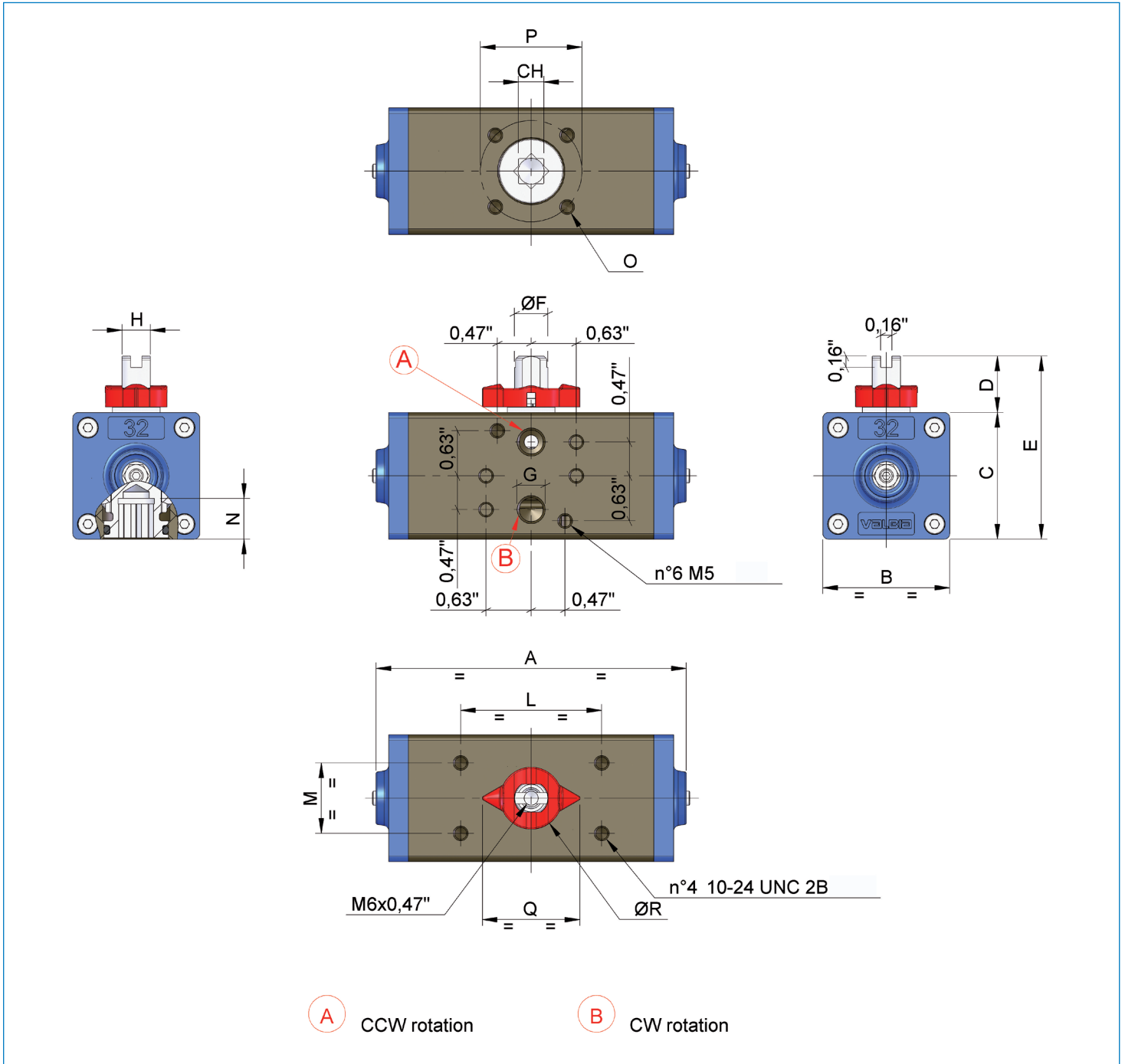

MOD.	PATTERN ISO 5211	CH mm	A	B	C	D	E	ØF	G NPT	H	L	M	N	O	P	Q	ØR
32	F03	9	4.33	1.77	1.77	0.79	2.56	0.46	1/8"	0.39	1.97	0.98	0.47	10-24 UNC 2Bx0.30	1.42	1.36	0.87

SERIES 82 DIMENSIONS FROM MOD.52 TO 230

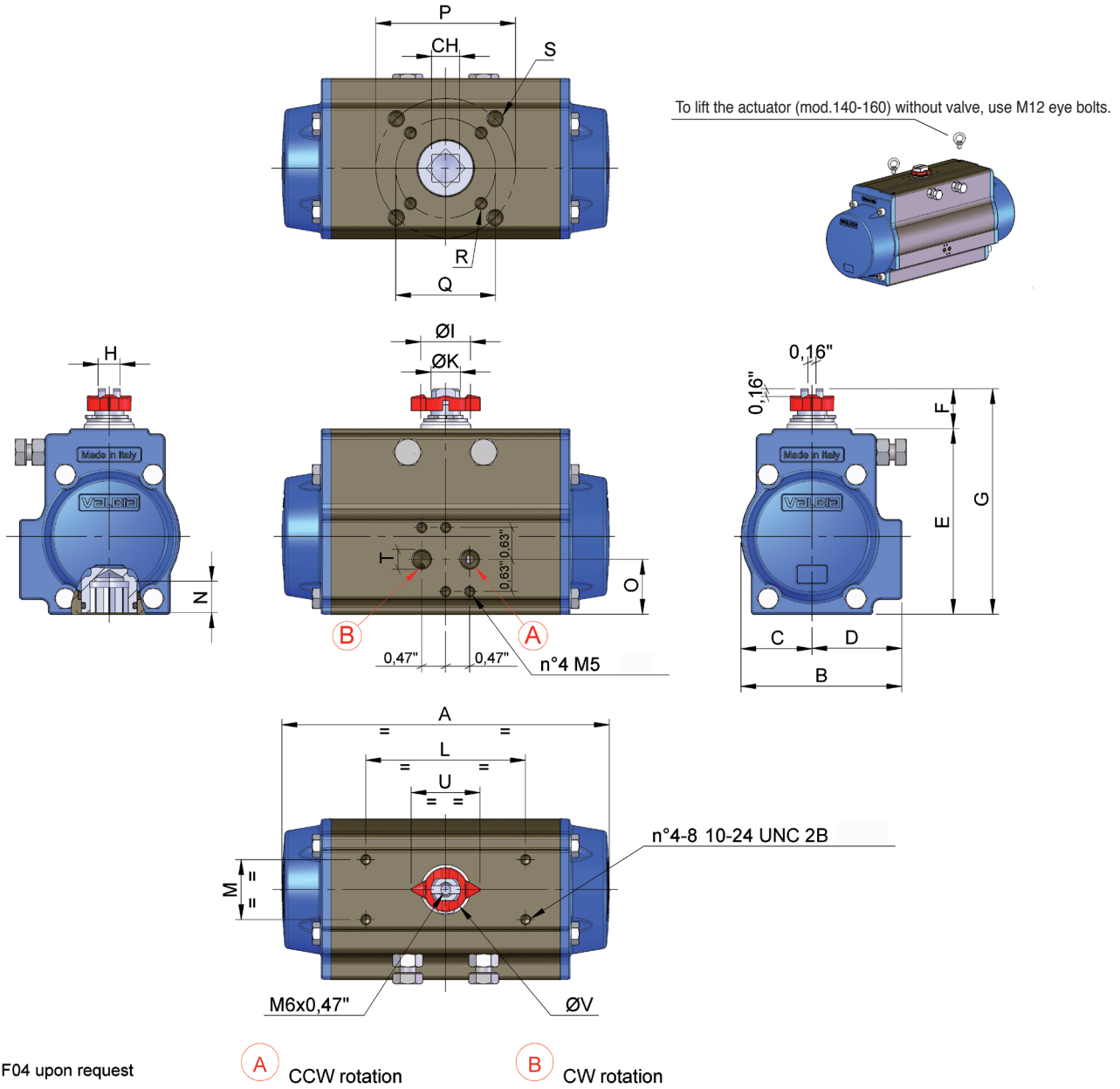

MOD.	PATTERN ISO 5211	CH mm	A	B	C	D	E	F	G	H	ØI	ØK	L	M	N	O	P	Q	R	S	T NPT	U	ØV
52	F03-F05 *	11	5.55	2.80	1.18	1.61	3.21	0.79	4.00	0.39	0.83	0.47	3.15	1.18	0.47	1.04	1.97	1.42	10-24 UNC 2Bx0.29"	1/4-20 UNC 2Bx0.35"	1/8"	1.36	0.87
63	F05 - F07 *	14	6.46	3.17	1.40	1.77	3.66	0.79	4.45	0.43	0.98	0.59	3.15	1.18	0.63	1.08	2.76	1.97	1/4-20 UNC 2Bx0.31"	5/16-18 UNC 2Bx0.47"	1/8"	1.36	0.87
75	F05 - F07	17	8.27	3.72	1.65	2.07	4.37	0.79	5.16	0.51	1.14	0.75	3.15	1.18	0.75	1.38	2.76	1.97	1/4-20 UNC 2Bx0.31"	5/16-18 UNC 2Bx0.47"	1/8"	1.65	1.14
85	F05 - F07	17	9.47	4.17	1.87	2.30	4.92	0.79	5.71	0.59	1.38	0.86	3.15	1.18	0.75	1.65	2.76	1.97	1/4-20 UNC 2Bx0.31"	5/16-18 UNC 2Bx0.47"	1/8"	1.65	1.14
100	F07 - F10	17	10.83	4.84	2.17	2.68	5.43	0.79	6.21	0.59	1.38	0.86	3.15	1.18	0.81	1.97	4.02	2.76	5/16-18 UNC 2Bx0.31"	3/8-16 UNC 2Bx0.55"	1/4"	1.65	1.14
115	F07 - F10	22	13.11	5.39	2.52	2.87	6.39	1.18	7.57	0.87	1.93	1.26	3.15/5.12	1.18	0.94	1.97	4.02	2.76	5/16-18 UNC 2Bx0.47"	3/8-16 UNC 2Bx0.59"	1/4"	2.52	1.73
125	F07 - F10	22	14.65	5.83	2.68	3.15	6.87	1.18	8.05	0.87	1.93	1.26	3.15/5.12	1.18	0.94	2.40	4.02	2.76	5/16-18 UNC 2Bx0.47"	3/8-16 UNC 2Bx0.59"	1/4"	2.52	1.73
140	F10 - F12	27	17.13	6.46	3.01	3.44	7.76	1.18	8.94	0.94	1.93	1.38	3.15/5.12	1.18	1.14	2.80	4.92	4.02	3/8-16 UNC 2Bx0.59"	1/2-13 UNC 2Bx0.71"	1/4"	2.52	1.73
160	F10 - F12	27	19.69	7.32	3.43	3.90	8.70	1.18	9.88	1.18	2.24	1.57	3.15/5.12	1.18	1.26	3.15	4.92	4.02	3/8-16 UNC 2Bx0.55"	1/2-13 UNC 2Bx0.67"	1/4"	3.17	2.36
180	F10 - F14	36	19.41	8.38	3.86	4.53	9.96	1.18	11.14	1.42	2.44	1.77	3.15/5.12	1.18	1.69	3.90	5.51	4.02	3/8-16 UNC 2Bx0.59"	5/8-11 UNC 2Bx0.98"	1/4"	3.17	2.36
200	F14	36	22.76	8.54	4.25	4.29	10.94	1.18	12.13	1.42	2.64	1.97	3.15/5.12	1.18	1.46	3.07	5.51	-	-	5/8-11 UNC 2Bx0.94"	1/4"	3.17	2.36
230	F16	** 46	27.17	9.78	4.88	4.90	12.80	1.18	13.98	1.42	2.64	1.97	3.15/5.12	1.18	1.97	3.62	6.50	-	-	3/4-10 UNC 2Bx1.14"	1/4"	3.17	2.36

** 45° square drive only.

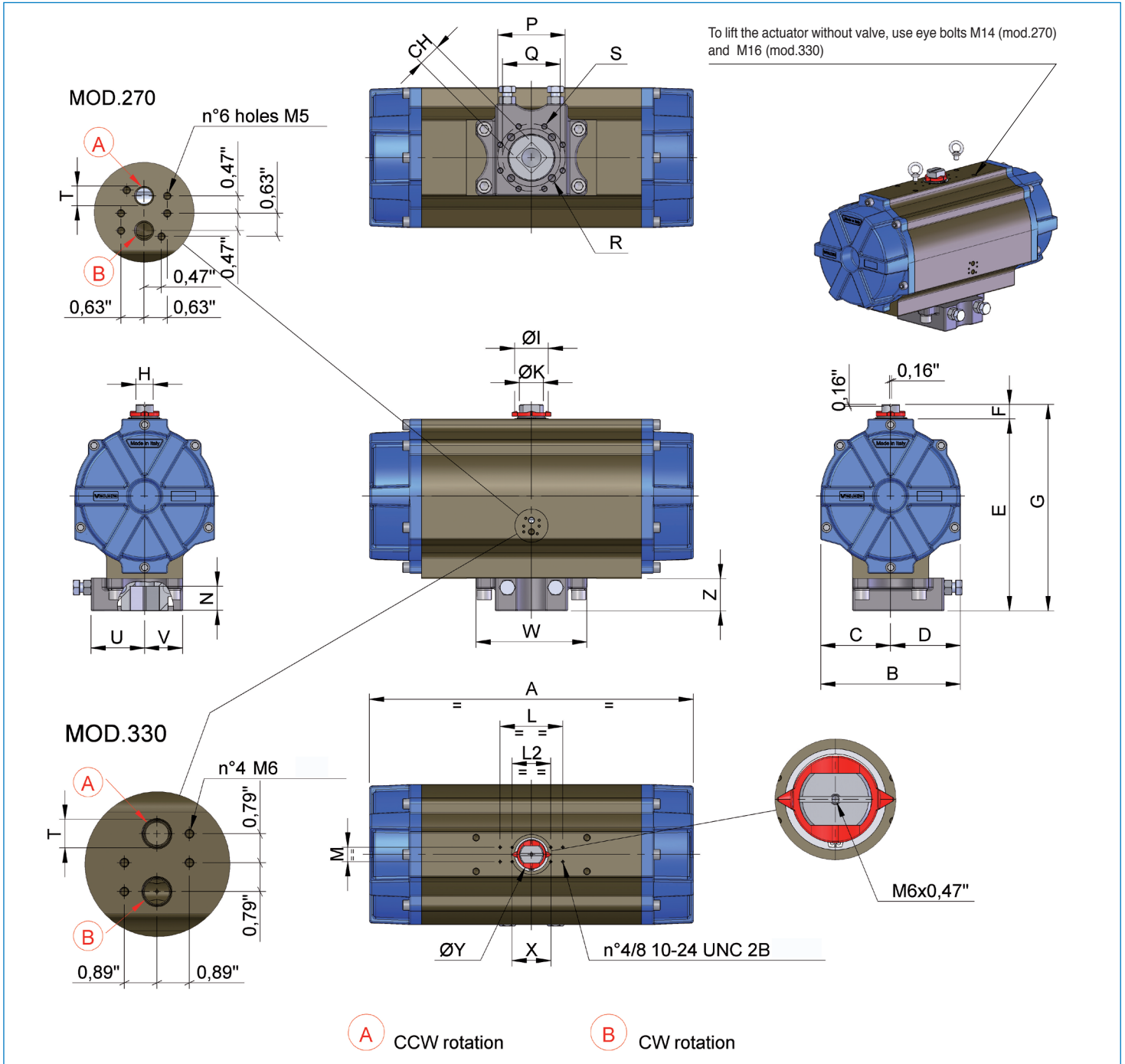

MOD.	PATTERN ISO 5211	CH mm	A	B	C	D	E	F	G	H	ØI	ØK	L	L2	M	N	P	Q	R	S	T NPT	U	V	W	Z	X	ØY	
270	F16	**	46	26.46	11.42	5.71	5.71	15.71	1.18	16.89	1.42	2.76	1.97	5.12	3.15	1.18	1.97	-	6.50	3/4-10 UNC 2Bx1.18"	-	1/4"	4.37	3.11	9.06	2.68	3.17	2.36
330	F16-F25	**	55	34.69	15.83	7.91	7.91	19.88	1.97	21.85	1.42	4.29	1.97	5.12	-	1.18	2.44	10	6.50	3/4-10 UNC 2Bx1.18"	5/8-11 UNC 2Bx1.02"	1/2"	5.08	5.32	11.69	3.74	3.17	2.36

** 45° square drive only.

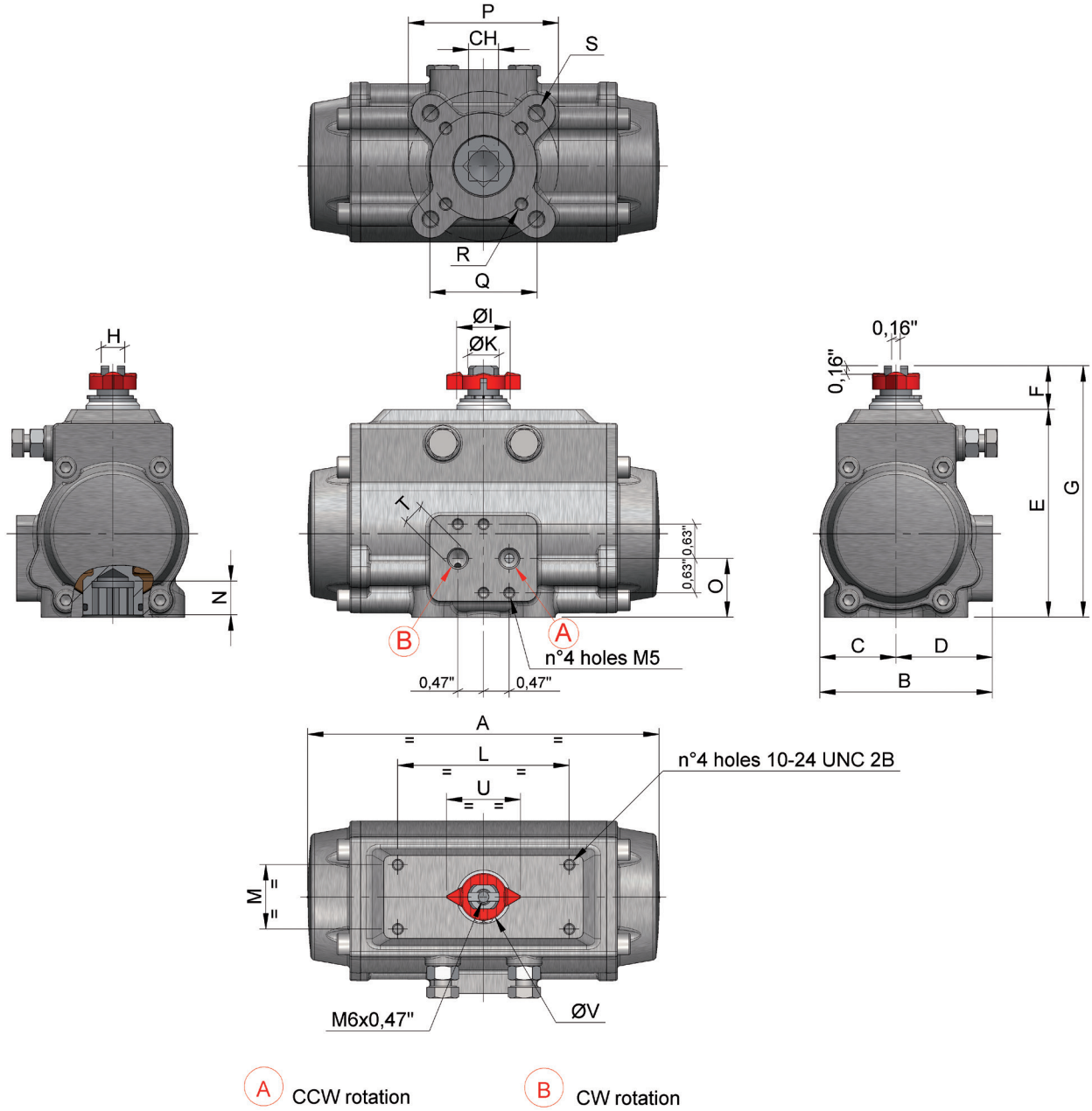

MOD.	PATTERN ISO 5211	CH mm	A	B	C	D	E	F	G	H	ØI	ØK	L	M	N	O	P	Q	R	S	T NPT	U	ØV
52	F03-F05	11	5.55	2.80	1.18	1.61	3.37	0.79	4.15	0.39	0.83	0.47	3.15	1.18	0.47	1.04	1.97	1.42	10-24 UNC 2Bx0.29"	1/4-20 UNC 2Bx0.35"	1/8"	1.36	0.87
63	F05-F07	14	6.46	3.17	1.40	1.77	3.82	0.79	4.61	0.43	0.98	0.59	3.15	1.18	0.63	1.08	2.76	1.97	1/4-20 UNC 2Bx0.31"	5/16-18 UNC 2Bx0.47"	1/8"	1.36	0.87
75	F05-F07	17	8.27	3.72	1.65	2.07	4.53	0.79	5.32	0.51	1.14	0.75	3.15	1.18	0.75	1.38	2.76	1.97	1/4-20 UNC 2Bx0.31"	5/16-18 UNC 2Bx0.47"	1/8"	1.65	1.14
85	F05-F07	17	9.47	4.17	1.87	2.30	5.08	0.79	5.87	0.59	1.38	0.86	3.15	1.18	0.75	1.65	2.76	1.97	1/4-20 UNC 2Bx0.31"	5/16-18 UNC 2Bx0.47"	1/8"	1.65	1.14
100	F07-F10	17	10.83	4.84	2.17	2.68	5.66	0.79	6.45	0.59	1.38	0.86	3.15	1.18	0.81	2.07	4.02	2.76	5/16-18 UNC 2Bx0.35"	3/8-16 UNC 2Bx0.55"	1/8"	1.65	1.14

DOUBLE ACTING ACTUATOR

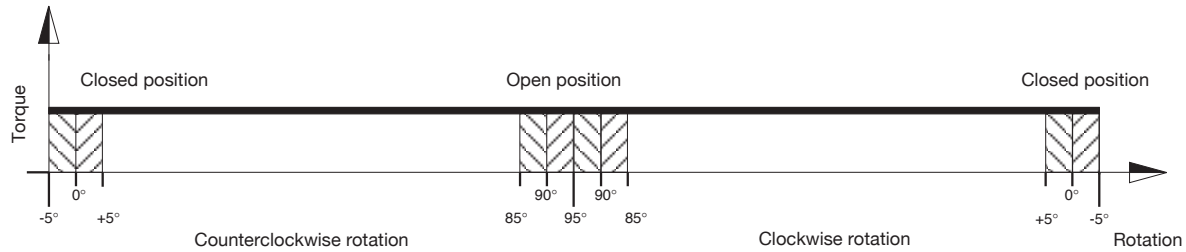
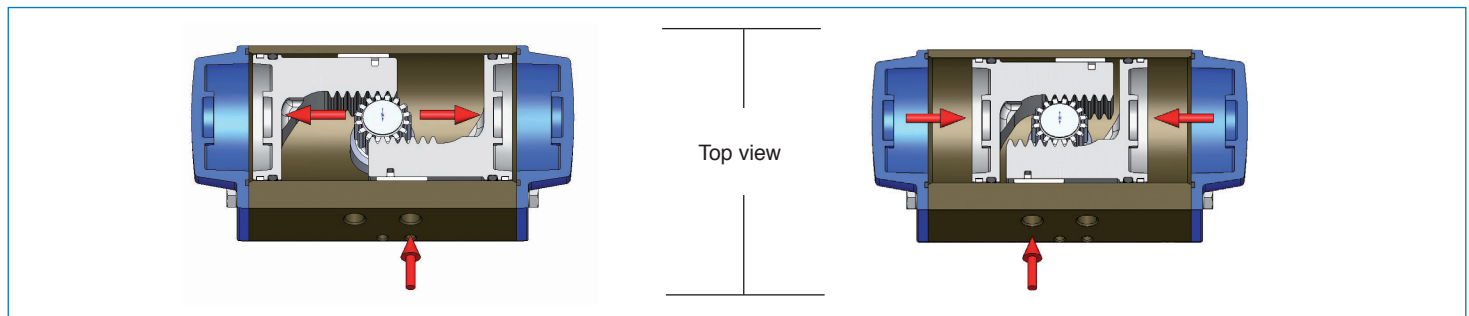

The torque of a double acting actuator remains consistent throughout the complete action.

The actuator can be sized using the following guidelines:

1. Define the maximum torque of the valve.
2. Increase the torque value by 25% - 50% to add a safety factory (subject to the type of valve and working conditions).
3. Use the torque chart considering the available air pressure find a torque value exact to or exceeding the one obtained.
4. Move horizontally in the chart to find sufficient actuator output torque.

TYPE	AIR SUPPLY PRESSURE (psi)							
	40	50	60	70	80	90	100	115
	DOUBLE ACTING ACTUATORS TORQUE OUTPUT (in-Lbs)							
DA 32	34	43	55	64	71	82	87	101
DA 52 *	88	112	133	158	178	201	227	263
DA 63 *	152	193	238	282	320	361	405	469
DA 75 *	283	356	435	513	586	659	736	851
DA 85 *	406	514	628	744	853	960	1072	1237
DA 100 *	645	814	989	1163	1333	1505	1681	1939
DA 115	1065	1344	1640	1932	2212	2488	2779	3211
DA 125	1402	1771	2153	2539	2905	3274	3650	4220
DA 140	2003	2504	3005	3506	4006	4509	5009	5764
DA 160	2804	3501	4196	4899	5596	6292	6987	8045
DA 180	3860	4825	5790	6746	7711	8661	9627	11081
DA 200	5198	6494	7796	9089	10393	11670	12972	14924
DA 230	8589	10738	12880	15031	17180	19289	21440	24671
DA 270	12625	15777	18935	22093	25246	28361	31511	36269
DA 330	22464	28083	33702	39321	44939	50476	56086	64555

* Valid also for stainless steel actuator.

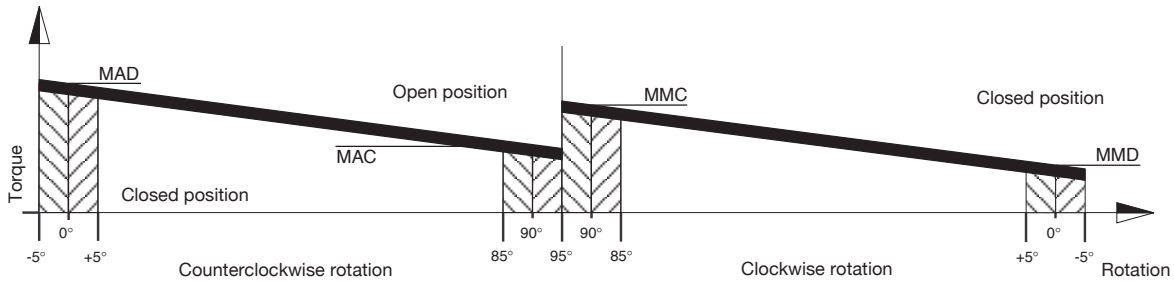
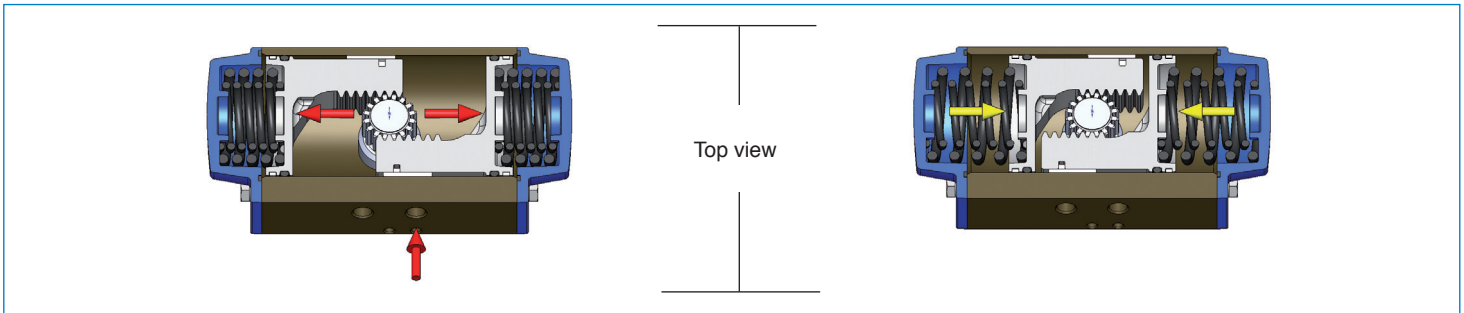

The output torque of a spring return actuator is not consistent but decreasing. This is due to the action of the springs. When compressed by the air pushing out the pistons, they accumulate energy which will be available in a decreasing way during the clockwise rotation inversion. The output torque given by the actuator is defined by four values.

- Opening rotation
 MAD = Actuator torque with unfolded springs
 MAC = Actuator torque with compressed springs.
 Closing rotation
 MMC = Torque with compressed springs.
 MMD = Torque with unfolded springs

The SR actuator can be sized using the following guidelines:

1. Define the maximum torque of the valve.
2. Increase the torque value by 25% - 50% to add a safety factor (subject to the type of valve and working conditions).
3. Use torque chart considering the available air pressure to find a sufficient actuator output torque by looking at the lower between the MMD and MAC values.
4. Move horizontally in the chart to find the actuator model required.

VALID FROM MOD. 52 TO MOD. 140 *

SPRING SETTING

SET STANDARD 05

SET	EXTERNAL SPRING	INTERNAL SPRING
01	1	1
02	2	-
03	1	2
04	2	1
05	2	2

VALID FROM MOD. 160 TO MOD. 200

SPRING SETTING

SET STANDARD 06

SET	EXTERNAL SPRING	CENTRAL SPRING	INTERNAL SPRING
01	-	2	-
02	2	-	-
03	1	2	-
04	2	-	2
05	2	2	-
06	2	2	2

VALID FROM MOD. 230 TO MOD. 330

SPRING SETTING

PRE-TENSIONED SPRING

SET	N° OF SPRINGS FOR EACH SIDE	
01	2/3	MOD.230 MOD.270 e 330
02	3/3	
03	3/4	
04	4/4	
05	4/5	
06	5/5	
07	5/6	
08	6/6	

* Valid also for stainless steel actuator from mod. 52 to mod. 100.

SR ACTUATORS TORQUE OUTPUT

MOD.	SET	SPRING TORQUE (in-Lbs)		AIR SUPPLY PRESSURE (psi)																
				40		50		60		70		80		90		100		115		
				SPRING RETURN ACTUATORS TORQUE OUTPUT (in-Lbs)																
0° MMD	90° MMC	0° MAD	90° MAC	0° MAD	90° MAC	0° MAD	90° MAC	0° MAD	90° MAC	0° MAD	90° MAC	0° MAD	90° MAC	0° MAD	90° MAC	0° MAD	90° MAC	0° MAD	90° MAC	
SR52	1	32	44	48	23	72	47	95	70	108	77									
	2	42	59			61	31	84	54	108	77									
	3	46	66					80	47	104	70	127	94	150	117					
	4	57	82					70	31	93	55	116	78	140	101	163	125			
	5	72	105							78	32	101	55	125	78	148	102	183	137	
SR63	1	44	85	92	38	134	80	176	122											
	2	58	109			120	56	162	98	204	140									
	3	71	128					149	79	191	121	233	162	275	204					
	4	85	152					136	54	177	96	219	138	261	180	303	222			
	5	111	196							151	53	193	95	235	136	276	178	339	241	
SR75	1	89	172	168	63	244	138	319	214											
	2	118	226			215	85	291	160	366	235									
	3	133	249					275	137	351	212	426	288	502	363					
	4	162	303					247	83	322	158	398	234	473	309	549	385			
	5	205	380							279	81	354	157	430	232	505	308	618	421	
SR85	1	143	242	238	109	349	219	460	330											
	2	176	298			316	163	427	274	537	384									
	3	215	361					387	211	498	322	609	432	720	543					
	4	248	417					354	155	465	265	576	376	687	487	797	633			
	5	321	536							392	146	503	257	614	368	725	478	891	645	
SR100	1	218	395	384	154	556	326	728	499											
	2	288	521			485	199	658	372	830	544									
	3	318	564					628	329	801	502	973	674	1146	847					
	4	389	691					558	203	730	375	903	548	1075	720	1248	893			
	5	489	860							630	206	802	378	975	551	1147	723	1406	982	
SR115	1	363	658	650	270	935	555	1220	840											
	2	449	835			848	378	1133	663	1419	949									
	3	538	957					1044	541	1329	827	1615	1112	1900	1397					
	4	625	1133					958	365	1243	650	1528	935	1813	1220	2098	1505			
	5	800	1432							1067	352	1352	637	1638	922	1923	1207	2350	1635	
SR125	1	470	877	850	328	1224	703	1599	1077											
	2	560	1040			1135	400	1400	840	2000	1883									
	3	718	1313					1351	640	1725	1015	2099	1389	2474	1763					
	4	808	1477					1261	477	1636	851	2010	1226	2384	1600	2758	1974			
	5	1055	1913							1388	415	1762	789	2136	1164	2511	1538	3072	2099	
SR140	1	726	1346	1240	508	1742	1010	2244	1512											
	2	815	1523			1642	821	2144	1323	2646	1825									
	3	1036	1958					1910	856	2412	1358	2914	1861	3408	2355					
	4	1134	2126					1810	668	2312	1170	2814	1672	3308	2166	3810	2668			
	5	1453	2728							1979	515	2481	1017	2975	1511	3477	2013	4233	2769	
SR160	1	735	1159	2036	1585	2741	2290													
	2	1053	1664			2405	1532	3085	2438											
	3	1266	1991			2184	1405	2863	2084	3552	2773									
	4	1637	2584					2465	1456	3153	2463	3859	2850							
	5	1788	2823							2985	1896	3691	2603	4405	3317					
	6	2372	3744								3080	1620	3795	2335	4474	3014	5528	4069		
SR180	1	903	1487	2540	1921	3239	2620													
	2	1416	2230			2691	1823	4089	3222											
	3	1611	2602			2487	1434	3885	2832	5275	4222									
	4	2319	3664					3133	1735	4523	3124	5222	3824							
	5	2319	3717							4523	3036									
	6	3222	5151									4266	2248	4965	2947	6364	4346	7762	5744	
SR200	1	1496	2222	3638	2895	4954	4211													
	2	2098	3124			4264	3211	5531	4477											
	3	2549	3788			3812	2556	5080	3823	6338	5081									
	4	2992	4620					4549	2885	5807	4144	7132	5468							
	5	3593	5346							5196	3418	6521	4742	7837	6058					
	6	4487	6842									5539	3150	6854	4465	8122	5732	10066	7677	
SR230	1	3443	5895	4124	1522	5682	3080	8789	6187											
	2	4124	7072			4956	1823	8063	4930											
	3	4815	8258					7328	3682	10444	6797									
	4	5505	9435					6603	2425	9718	5541	11276	7098							
	5	6196	10612					5868	1177	8984	4293	10541	5850	12090	7399					
	6	6877	11789							8258	3036	9815	4594	11364	6142	14480	9258	17586	12364	
SR270	1	4478	7001	8096	5530	11308	8742	14548	11982											
	2	5372	8399	7141	4061	10353	7273	13627	10513											
	3	6266	9798	5229	2592	9397	5804	12637	9044	15877	12284									
	4	7169	11196			8450	4344	11690	7583	14930	10823	18141	14036							
	5	8063	12595					10734	6114	13974	9354	17185	12566	20397	18478					
	6	8957	13993					9778	4645	13018	7885	16230	11097	19441	14308					
	7	9851	15400					8823	3216	12062	6416	15275	9628	18486	12839	21717	16071			
	8	10745	16799					7867	1707	11107	4947	14319	8159	17530	11370	20762	14602	25593	19434	
SR330	1	7824	12143	12046	7452	16117	11524	24260	19666											
	2	9382	14577	10382	4868	14453	8939	22596	17082											
	3	10948	17002	8718	2292	12789	6364	20932	14506	29075	22649									
	4	12515	19436			11134	3779	19277	11922	27420	20065	31491	24136							
	5	14082	21861					17613	9346	25756	17489	29827	21560	33898	25632					
	6	15639	24295					15949	6762	24092	14905	28163	18976	32234	23047					
	7	17206	26720					14294	4186	22437	12329	26508	16400	30579	20472	38713	28606			
	8	18772	29154							20773	9745	24844	13816	28915	17887	37049	26021	45192	34164	



		CYCLE TIME (SEC)															
TYPE	MODEL																
		32	52	63	75	85	100	115	125	140	160	180	200	230	270	330	
0°-90° ROT.	COUNTERCLOCKWISE ROTATION (DA)	CCW	0.03	0.07	0.11	0.18	0.36	0.38	0.60	0.80	1.13	1.43	1.99	3.08	4.15	6.16	5.50
	CLOCKWISE ROTATION (DA)	CW	0.03	0.05	0.10	0.15	0.25	0.34	0.54	0.70	0.94	1.25	1.80	2.41	3.80	5.47	5.50
	COUNTERCLOCKWISE ROTATION (SR)	CCW	-	0.07	0.13	0.32	0.32	0.54	0.92	1.20	1.64	2.27	3.08	3.58	6.20	8.97	6.40
	CLOCKWISE ROTATION (SR)	CW	-	0.07	0.13	0.22	0.30	0.48	0.75	0.94	1.25	1.60	2.38	2.80	5.40	6.62	7.40
0°-180° ROT.	COUNTERCLOCKWISE ROTATION (DA)	CCW	-	0.08	0.14	0.34	0.42	0.64	1.11	1.87	2.95	3.03	-	-	-	-	-
	CLOCKWISE ROTATION (DA)	CW	-	0.06	0.12	0.25	0.39	0.62	1.08	1.13	2.03	2.29	-	-	-	-	-

SERIES 82-83 WEIGHT CHART (Lbs)																
TYPE	MODEL															
		32	52	63	75	85	100	115	125	140	160	180	200	230	270	330
90° DA		1.08	2.47	3.66	6.13	8.60	12.13	19.51	23.81	35.94	47.96	63.95	81.59	128.99	182.29	370.44
90° SR		-	2.87	4.34	7.47	10.58	15.44	25.25	31.05	48.07	65.05	87.98	121.28	156.56	221.10	460.85
180° DA		-	3.75	5.51	9.26	13.19	18.81	30.10	38.26	55.11	68.78	-	-	-	-	-

SERIES 84 STAINLESS STEEL ACTUATOR WEIGHT CHART (Lbs)						
TYPE	MODEL					
		52	63	75	85	100
90° DA		4.98	6.90	10.94	16.54	22.49
90° SR		5.38	7.59	12.28	18.41	25.86

ACTUATOR AIR CONSUMPTION CHART																	
		(in ³) CUBIC INCHES															
TYPE	MODEL																
		32	52	63	75	85	100	115	125	140	160	180	200	230	270	330	
0°-90° ROT.	COUNTERCLOCKWISE ROTATION (DA/SR)	CCW	2.44	6.1	11.6	21.96	31.12	48.2	78.72	99.47	137.91	220.3	282.54	347.83	651.73	915.35	1556.11
	CLOCKWISE ROTATION (DA)	CW	1.83	7.93	14.04	26.85	39.06	61.02	104.35	134.86	192.83	306.33	402.75	643.8	918.4	1086.22	2697.25
0°-180° ROT.	COUNTERCLOCKWISE ROTATION (DA)	CCW	-	10.37	20.13	36.61	54.92	83.6	130	176.96	299	329.52	-	-	-	-	
	CLOCKWISE ROTATION (DA)	CW	-	9.76	17.7	34.17	50.65	80.55	137.3	183	238	385.67	-	-	-	-	

To obtain the air consumption in NI/min, multiply the value in the chart for the correct parameters. That is to say for the supplied absolute pressure and the number of strokes in a minute.

GENERAL SPECIFICATIONS

Valbia provides a wide range of quarter-turn single-phase electric actuators, available with different voltages of power supply (12V/24V/100-240V) and frequency (50/60 Hz), with CE UL and CSA certifications and different levels of protection enclosure (IP-UL Type).

Valbia electric actuators are suitable for the automation of a great variety of ball and butterfly valves, with torque values from 90 to 3100 lbs-In.

Valbia selects, manufactures and uses high quality components to assure high performances:

- The electronic circuit boards are assembled in Italy using state of the art components. The motor adjusts its speed at the load variations in order to consistently maintain the specified cycle time.
- The torque limiter and the heaters are both included in the standard version and are always automatically operating when the actuator is powered, to ensure a continuous protection against condensation and over-torque.
- The gear train is made of two steel and techno-polymer gear wheels, inserted in a strong die-cast aluminum structure and sustained by hardened steel pinions mounted on self-lubricating bushes, to provide a strong mechanical construction.
- The Valbia electric actuators are all designed with an ISO 5211 standard bottom connection pattern, in order to allow the direct mount of all ISO 5211 designed valve.

Valbia manufactures two series of electric actuators:

- The 85 series, with a technopolymer enclosure.
- The 86 series, with a powder coated aluminum enclosure.

In addition, Valbia offers a wide range of special versions designed to provide effective solutions for special applications.

VERSION	VOLTAGE	VB010		VB015		VB030		VB060		VB110		VB190		VB270		VB350	
		858	85	86	85	86	85	86	85	86	85	86	85	86	85	86	
ON/OFF	100-240V	• **	•		•	•	•	•	•	•	•	•	•	•	•	•	•
	24V	• **	•		•	•	•	•	•	•	•	•	•	•	•	•	•
	12V		•		•	•	•	•	•	•	•	•	•	•	•	•	•
BATTERY BACKUP	100-240V				•	•	•	•	•	•	•	•	•	•	•	•	•
	24V				•	•	•	•	•	•	•	•	•	•	•	•	•
	12V																
POSITIONER	100-240V				•	•	•	•	•	•	•	•	•	•	•	•	•
	24V				•	•	•	•	•	•	•	•	•	•	•	•	•
	12V				•	•	•	•	•	•	•	•	•	•	•	•	•
BATTERY BACKUP+ POSITIONER	100-240V				•	•	•	•	•	•	•	•	•	•	•	•	•
	24V				•	•	•	•	•	•	•	•	•	•	•	•	•
	12V																
THREE POSITIONS	100-240V				•	•	•	•	•	•	•	•	•	•	•	•	•
	24V				•	•	•	•	•	•	•	•	•	•	•	•	•
THREE POSITIONS + BATTERY BACKUP+	100-240V				•	•	•	•	•	•	•	•	•	•	•	•	•
	24V				•	•	•	•	•	•	•	•	•	•	•	•	•

** 110V only.

ELECTRIC ACTUATOR VERSIONS

Standard 0°-90° rotation

Also available with adjustable rotation up to 270° upon request (85 series).

Special version with std (4-20mA or 0-10 V) or reverse (20-4mA or 10-0V) positioner

The modulating version can be controlled by a current (4-20 mA) or voltage (0-10V) command. The proportional control allows a resolution command of 1.3°, with a positioning tolerance of less than 3% of the potentiometer full scale.

Special version with battery backup for fail-safe operation

This special version is available for ON/OFF standard version, for the positioner version, and for the three positions version. Battery operation is immediately activated. As soon as the power supply is interrupted, the battery will operate the actuator in one of the following modes:

- For the ON/OFF standard version: fail close, fail open, or complete the interrupted cycle.
- For the version with positioner: fail open or fail close.

Special version with three positions - Standard version 0° - 90° (on request 0° - 180° / 0° - 270°)

This version is designed for special applications: it allows to set up 3 different limit switch positions: open, middle and closed.

In use of installation in areas subject to vibrations, please contact our sales department.

85 SERIES ELECTRIC ACTUATOR

MANUAL OVERRIDE

CONTROL BOARD

POWER SUPPLY BOARD

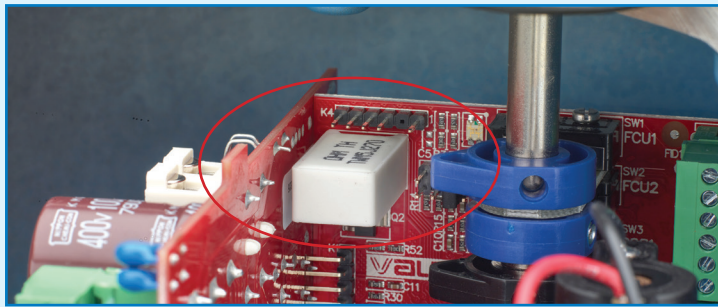
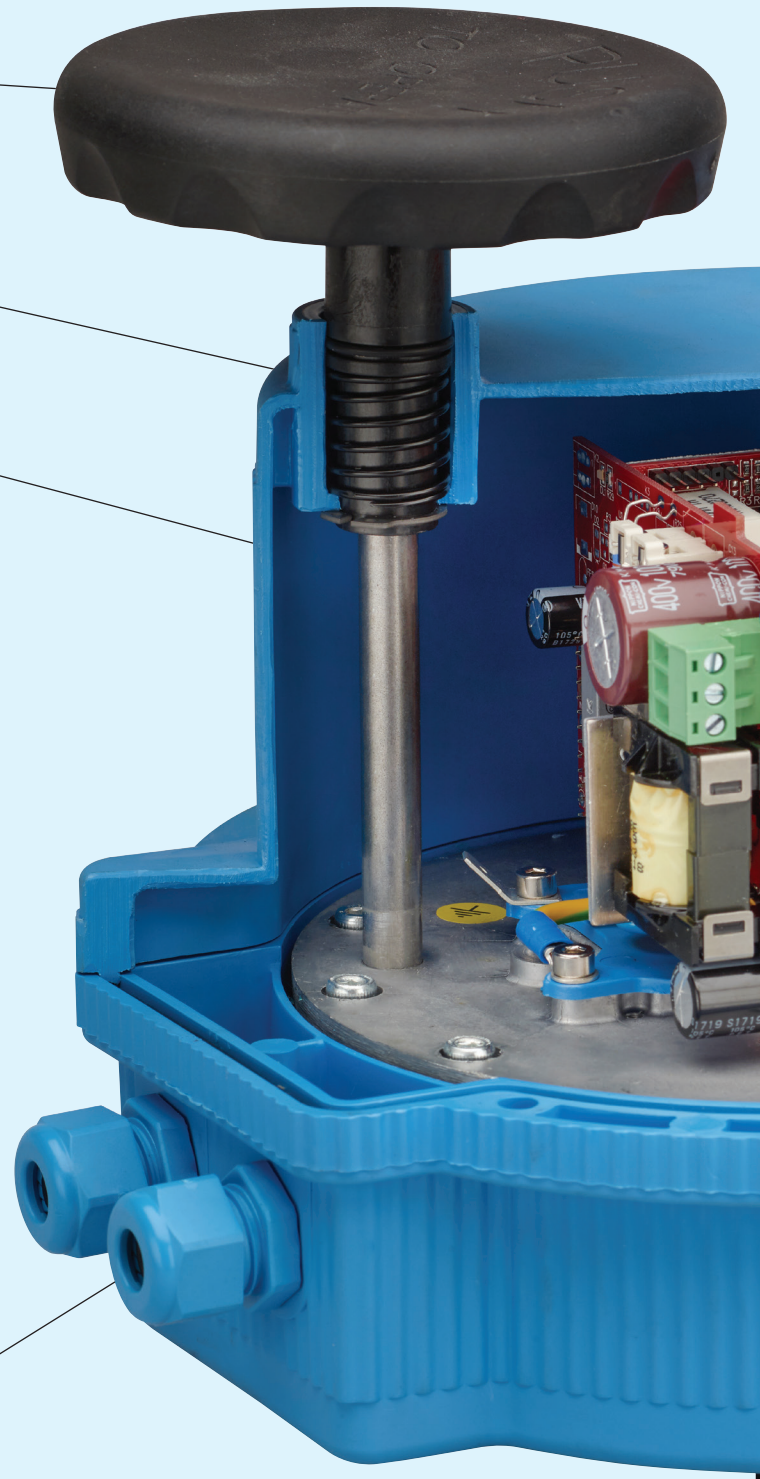

HEATERS:

- Managed by the control board to guarantee the optimal internal temperature and avoid condensation.

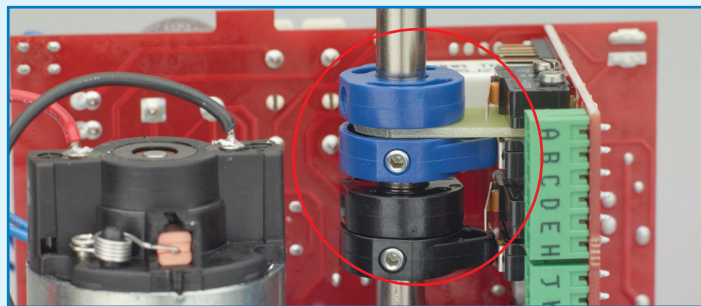

POSITION CAMS:

- Black cams: limit switches open and close adjustment.
- Blue cams: additional limit switches open and close adjustment.

PG 11 ELECTRIC CONNECTIONS

TECHNOPOLYMER ENCLOSURE

POSITION INDICATOR

DC MOTOR

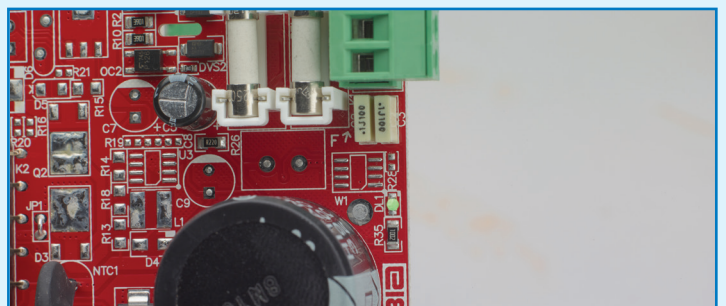
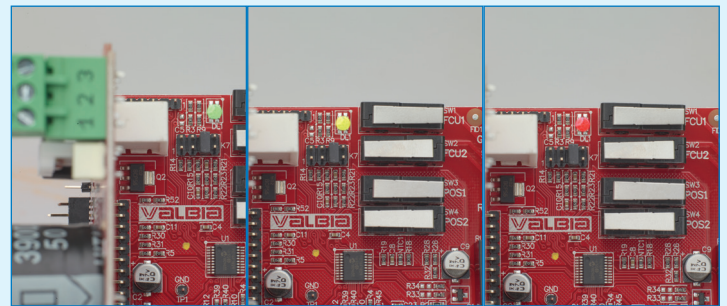
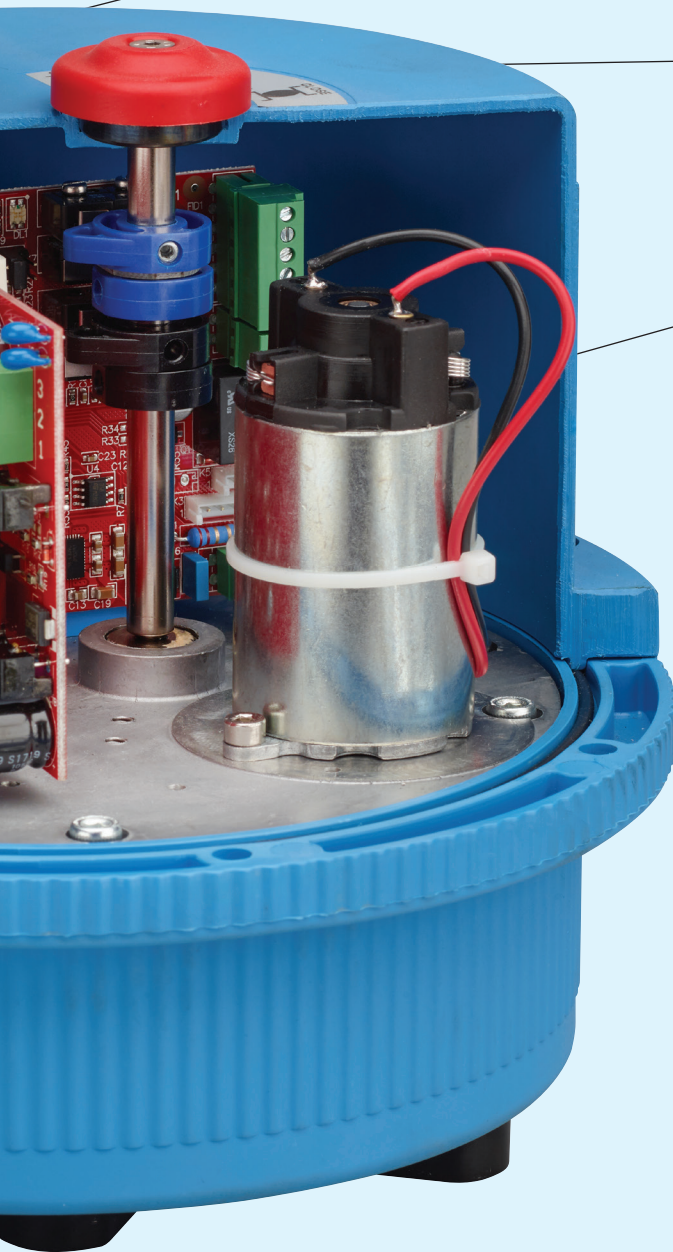

LED lights to indicate: power supply ON (green), actuator working conditions (yellow) and fault (red).

TECHNICAL DATA SERIES 85

MODEL	VB010	VB015	VB030	VB060	VB110	VB190	VB270	VB350	
MAX WORKING TORQUE (IN-LBS)	89	133	266	530	975	1680	2390	3100	
NOMINAL TENSION (V)	LOW VOLTAGE	NOT AVAILABLE	12V AC/DC	12V AC/DC	12V AC/DC	12V AC/DC	12V AC/DC	12V AC/DC	
	HIGH VOLTAGE	110V AC	100-240V AC	100-240V AC	100-240V AC	100-240V AC	100-240V AC	100-240V AC	
WORKING TIME (sec)	8 (sec. dc) 6.5 sec (ac)	10	8	9	27	27	50	50	
TORQUE LIMITER	STD	STD	STD	STD	STD	STD	STD	STD	
DUTY RATING	75%	12V AC/24V AC 12V DC/24V DC 100-240V AC	50% 24V AC/DC 100-240V AC	50% 24V AC/DC 100-240V AC	50% 24V AC/DC 100-240V AC	50% 24V AC/DC 100-240V AC	50% 24V AC/DC 100-240V AC	50% 24V AC/DC 100-240V AC	50% 24V AC/DC 100-240V AC
PROTECTION	IP65/Type4	IP65/Type4	IP67/Type4x	IP67/Type4x	IP67/Type4x	IP67/Type4x	IP67/Type4x	IP67/Type4x	
APPROVALS	CE	CE & UL	CE, UL & CSA	CE, UL & CSA	CE, UL & CSA	CE, UL & CSA	CE, UL & CSA	CE, UL & CSA	
ENCLOSURE	TECHNOPOLYMER	TECHNOPOLYMER	TECHNOPOLYMER	TECHNOPOLYMER	TECHNOPOLYMER	TECHNOPOLYMER	TECHNOPOLYMER	TECHNOPOLYMER	
ROTATION	90°	90°	90°	90°	90°	90°	90°	90°	
SPECIAL ROTATION	NOT AVAILABLE	180°	180° or 270°	180° or 270°	180° or 270°	180° or 270°	180° or 270°	180° or 270°	
MANUAL OVERRIDE	STD	STD	STD	STD	STD	STD	STD	STD	
POSITION INDICATOR	STD	STD	STD	STD	STD	STD	STD	STD	
WORKING TEMPERATURE	+23°F + 131°F	-4°F - 131°F	-4°F - 131°F	-4°F - 131°F	-4°F - 131°F	-4°F - 131°F	-4°F - 131°F	-4°F - 131°F	
HEATER	STD WIRED	STD	STD	STD	STD	STD	STD	STD	
AUXILIARY LIMIT SWITCHES	n°1 STD (type SPDT)	* n°2 STD (type SPDT)	* n°2 STD (type SPDT)	n°2 STD (type SPDT)	n°2 STD (type SPDT)	n°2 STD (type SPDT)	n°2 STD (type SPDT)	n°2 STD (type SPDT)	
PATTERN ISO 5211	F03-F05	F03-F05	F03-F05	F05-F07	F07-F10	F07-F10	F07-F10	F07-F10	
SQUARE DRIVE (mm)	11	11	11	14	17	17	22	22	
SPECIAL SQUARE DRIVE UPON REQUEST (mm)	9	9	9-14	11-17	14-22	14-22	17	17	
FAIL-SAFE OPERATION (BATTERY BACKUP)	NOT AVAILABLE	NOT AVAILABLE	NOT AVAILABLE	UPON REQUEST	UPON REQUEST	UPON REQUEST	UPON REQUEST	UPON REQUEST	
STD (4~20mA or 0~10 VDC) REVERSE (20~4mA or 10~0 VDC) MODE POSITIONER	NOT AVAILABLE	NOT AVAILABLE	UPON REQUEST	UPON REQUEST	UPON REQUEST	UPON REQUEST	UPON REQUEST	UPON REQUEST	
THREE POSITIONS	NOT AVAILABLE	NOT AVAILABLE	UPON REQUEST	UPON REQUEST	UPON REQUEST	UPON REQUEST	UPON REQUEST	UPON REQUEST	
ROTARY POTENTIOMETER (5K Ω 1W)	NOT AVAILABLE	UPON REQUEST	UPON REQUEST	UPON REQUEST	UPON REQUEST	UPON REQUEST	UPON REQUEST	UPON REQUEST	
ELECTRICAL CONNECTIONS - STANDARD**	PIG TAIL WIRE	PG11	PG11	PG11	PG11	PG11	PG11	PG11	
WEIGHT (Lbs)	1.65	3.09	5.05	7.28	10.80	10.80	13.23	13.23	

* F04 or F07 upon request.

** 1/2" Conduit - Optional.

POWER CONSUMPTION																
MODEL	VB010	VB015	VB030	VB060	VB110	VB190	VB270	VB350								
NOMINAL VOLTAGE	110V AC - 60Hz	100-240V AC														
VERSION H	ABSORBED CURRENT	0.41 A	0.3-0.19 A	0.4-0.2 A	0.6-0.3 A	0.4-0.2 A	0.6-0.3 A	0.6-0.3 A	0.75-0.4 A							
	ABSORBED POWER	45 VA	30-46 VA	40-48 VA	60-72 VA	40-48 VA	60-72 VA	60-72 VA	75-96 VA							
	NOMINAL VOLTAGE	24V AC/DC	12V AC/DC	24V AC/DC	12V AC/DC	24V AC/DC	12V AC/DC	24V AC/DC	12V AC/DC	24V AC/DC	12V AC/DC	24V AC/DC	12V AC/DC	24V AC/DC	12V AC/DC	24V AC/DC
VERSION L	ABSORBED CURRENT	0.6 A	1.2 A	0.6 A	2.2-1.8 A	1-0.7 A	3.8-2.85 A	1.8-1.2 A	2.2-1.8 A	1-0.7 A	3.8-2.85 A	1.8-1.2 A	3.8-2.85 A	1.8-1.2 A	4.75-3.65 A	1.95-1.65 A
	ABSORBED POWER	8.5-5 VA	15 VA	26.5-22 VA	24-17 VA	46-34 VA	43-29 VA	26.5-22 VA	24-17 VA	46-34 VA	43-29 VA	46-34 VA	43-29 VA	57-44 VA	47-40 VA	
	FREQUENCY	50/60 HZ														

MOD. VB010

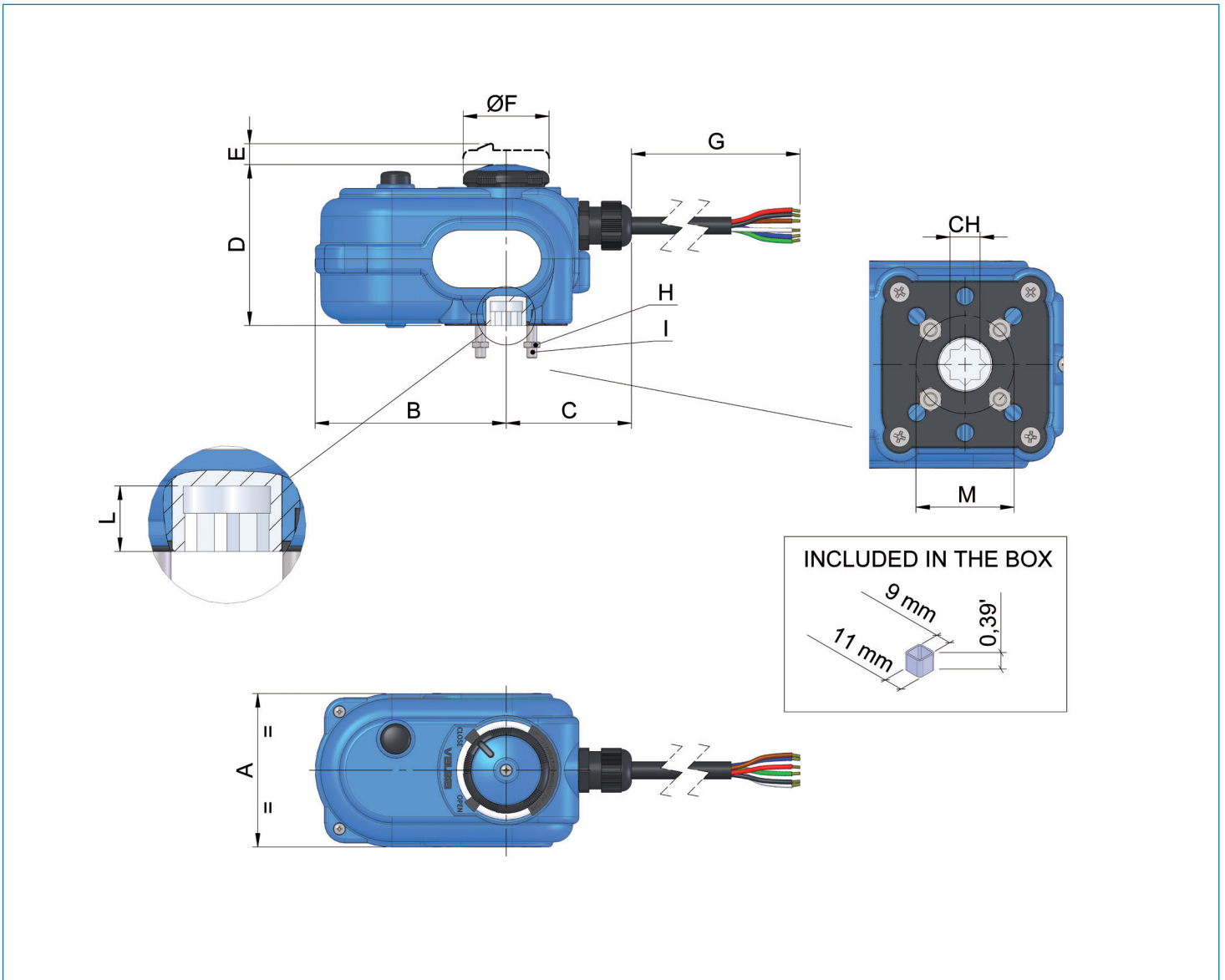

MOD.	ISO 5211 PATTERN	CH mm	A	B	C	D	E	F	G	H	I	L	M
VB010	F03-F05	9 or 11	2.99	3.72	2.44	3.15	0.28	1.69	31.5	M5	M5x0.63*	0.47	1.42

* Pre-mounted screw.

MOD. VB015

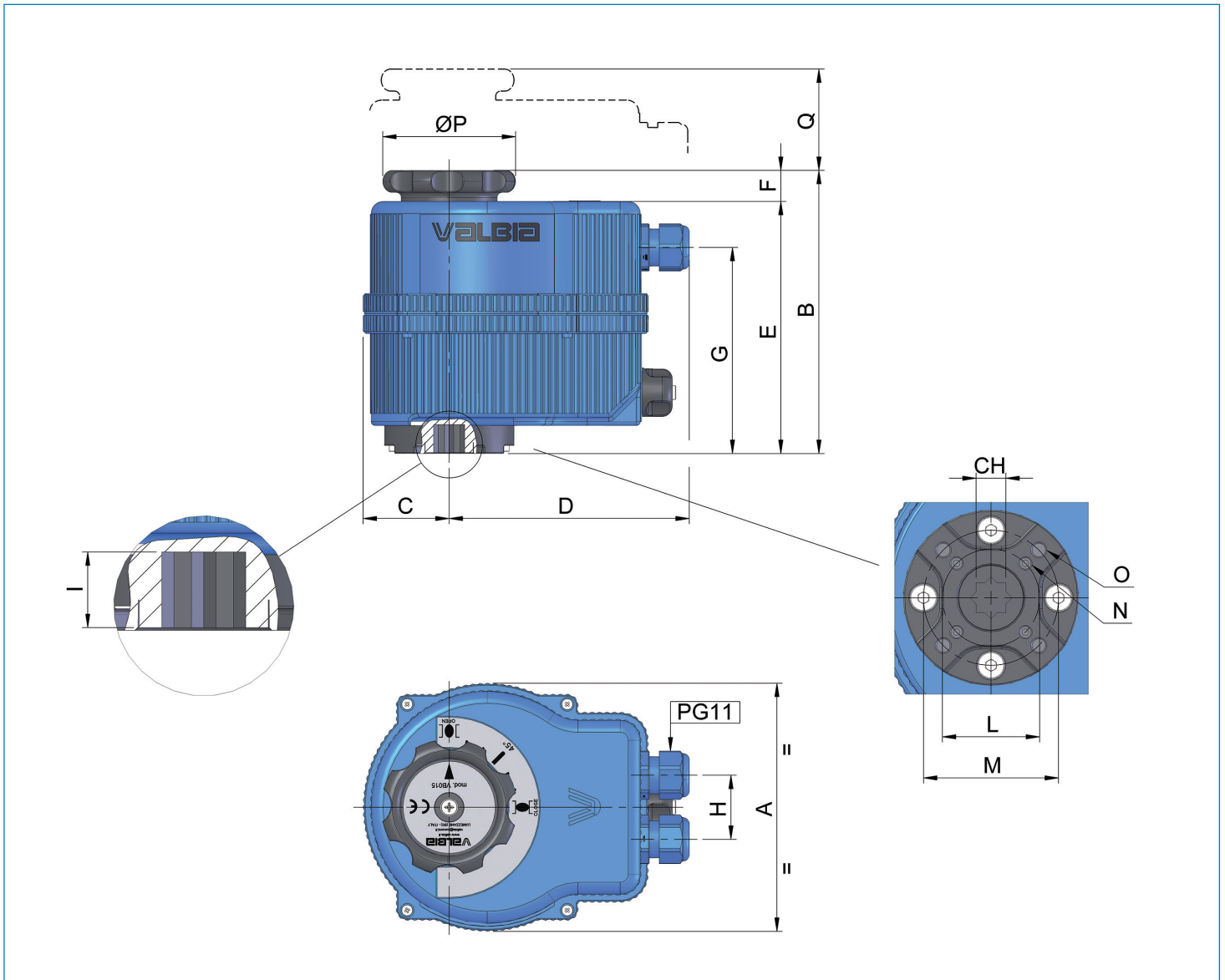

MOD.	ISO 5211 PATTERN	CH mm	A	B	C	D	E	F	G	H	I	L	M	N	O	$\varnothing P$	Q
VB015	* F03 - F05	11	4.84	5.57	1.67	4.74	4.96	0.61	4.06	1.26	0.55	1.42	1.97	10-24 UNC 2BX0.47	1/4-20 UNC 2BX0.51	2.68	2.56

* Upon request F04 or F07.

MOD. VB030 – VB350

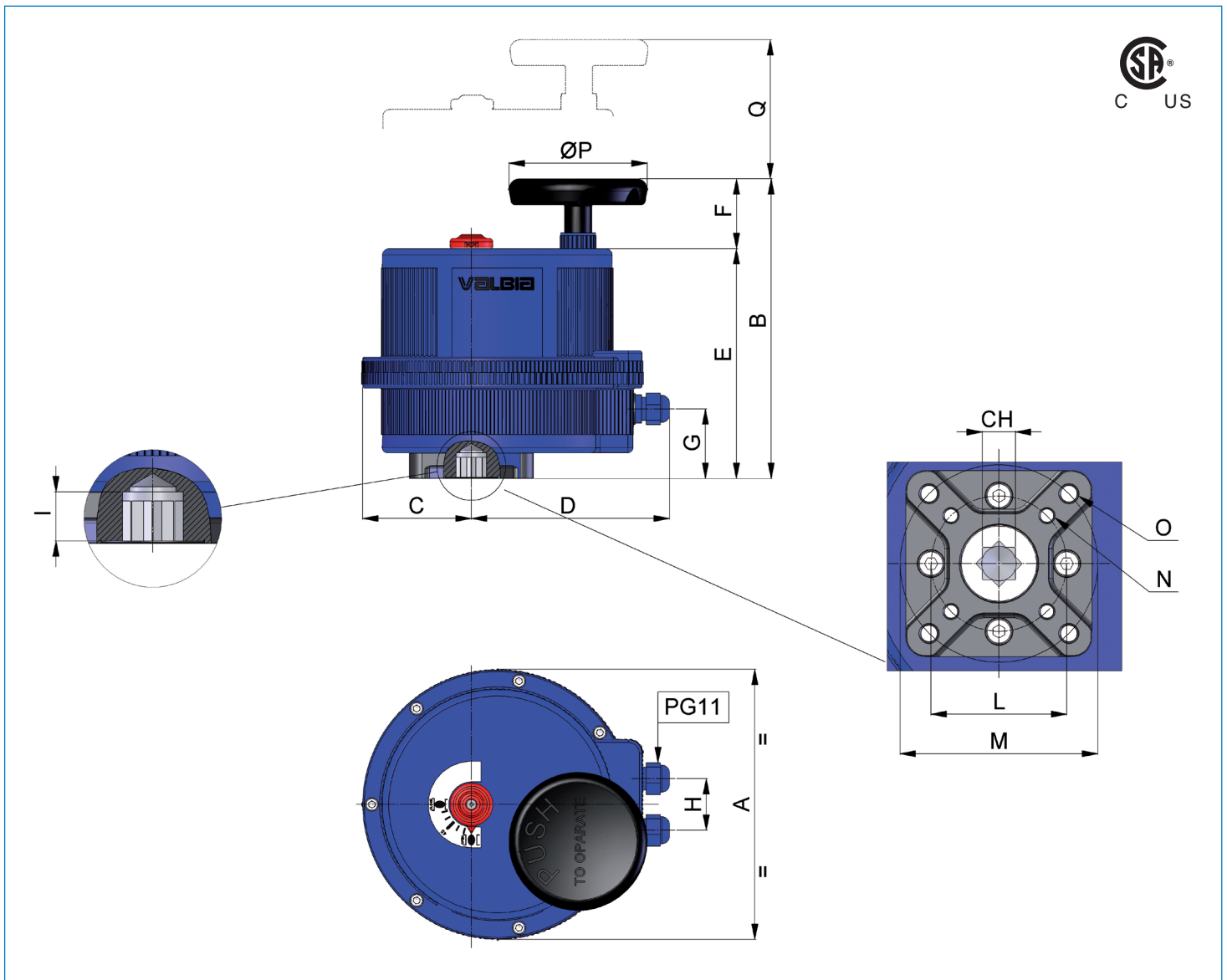

MOD.	ISO 5211 PATTERN	CH mm	A	B	C	D	E	F	G	H	I	L	M	N	O	ØP	Q
VB030	* F03 - F05	11	6.18	7.40	2.38	5.10	5.75	1.65	1.30	1.42	0.47	1.42	1.97	10-24 UNC 2BX0.47	1/4-20 UNC 2BX0.51	2.56	3.94
VB060	F05 - F07	14	7.28	8.46	2.66	5.77	6.81	1.65	2.01	1.42	0.63	1.97	2.76	1/4-20 UNC 2BX0.59	5/16-18 UNC 2BX0.63	2.56	4.33
VB110	F07 - F10	17	8.31	9.14	3.31	6.02	7.01	2.13	2.13	1.58	0.75	2.76	4.02	5/16-18 UNC 2BX0.75	3/8-16 UNC 2BX0.75	4.33	4.53
VB190	F07 - F10	17	8.31	9.14	3.31	6.02	7.01	2.13	2.13	1.58	0.75	2.76	4.02	5/16-18 UNC 2BX0.75	3/8-16 UNC 2BX0.75	4.33	4.53
VB270	F07 - F10	22	8.74	9.19	3.03	6.69	7.17	2.03	2.13	1.58	0.95	2.76	4.02	5/16-18 UNC 2BX0.75	3/8-16 UNC 2BX0.75	4.33	4.53
VB350	F07 - F10	22	8.74	9.19	3.03	6.69	7.17	2.03	2.13	1.58	0.95	2.76	4.02	5/16-18 UNC 2BX0.79	3/8-16 UNC 2BX0.75	4.33	4.53

* Upon request F04 or F07.

86 SERIES ELECTRIC ACTUATOR

ALUMINUM ALLOY ENCLOSURE WITH POLYESTER POWDER COATING

CONTROL BOARD

POWER SUPPLY BOARD

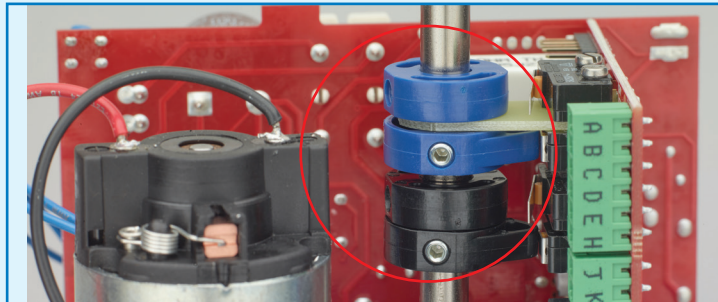

POSITION CAMS:

- Black cams: limit switches open and close adjustment.
- Blue cams: additional limit switches open and close adjustment.

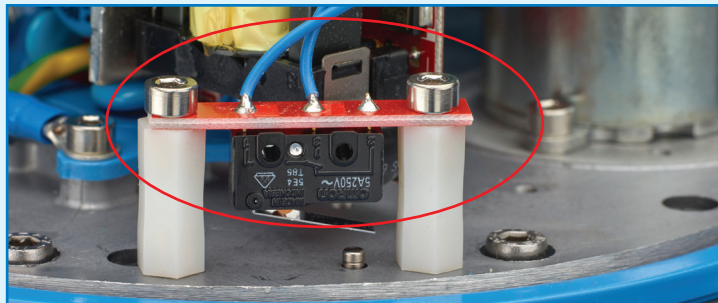

SNAP SWITCH (only for mod. VB110M - VB350M):

- To avoid the motor automatic rotation when the actuator is in manual mode.



MANUAL OVERRIDE SWITCH (only for mod. VB110M - VB350M):

- Engages and disengages the manual override.

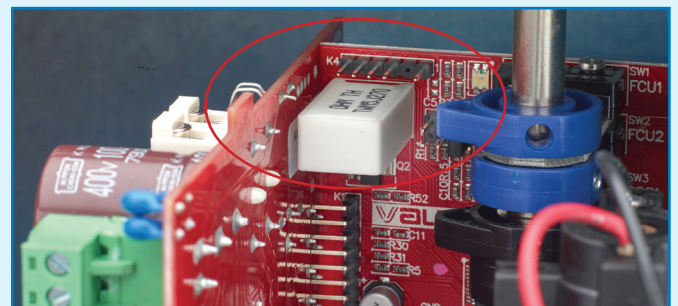

HEATER:

- Managed by the control board to guarantee the optimal internal temperature and avoid condensation.



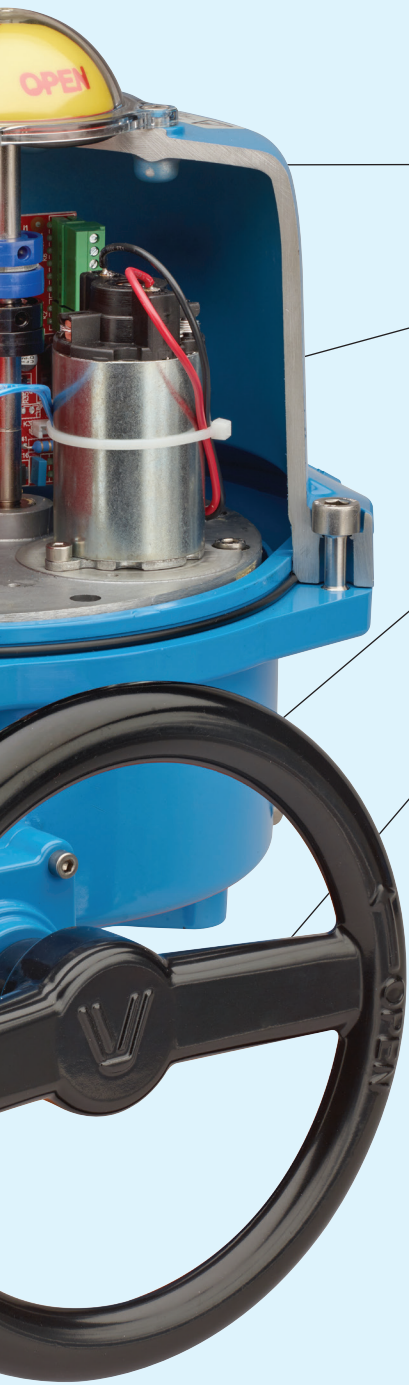

- DOME POSITION INDICATOR
- DC MOTOR
- OPEN/CLOSED POSITION ADJUSTMENT BOLTS
- MANUAL OVERRIDE



CAPTIVE COVER BOLT:

- Cover bolts are specially designed to prevent losing them during maintenance or installation.
- All external bolts are stainless steel.



EASY COVER OPENING

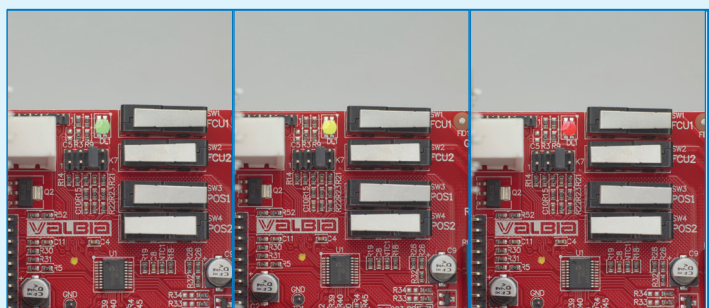
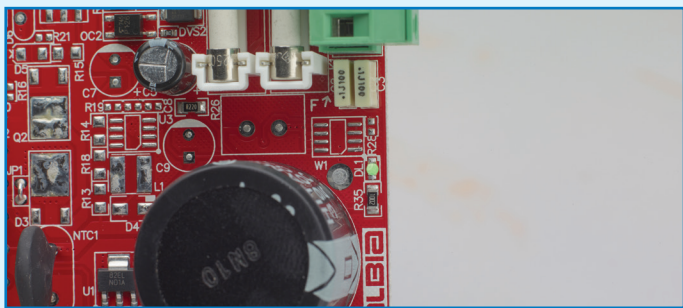

LED lights to indicate: power supply ON (green), actuator working conditions (yellow) and fault (red).

86 SERIES ELECTRIC ACTUATORS

MODEL		VB030M	VB060M	VB110M	VB190M	VB270M	VB350M
MAX WORKING TORQUE (in-Lbs)		266	530	975	1680	2390	3100
NOMINAL VOLTAGE (V)	LOW VOLTAGE	12V AC/DC	12V AC/DC	12V AC/DC	12V AC/DC	12V AC/DC	12V AC/DC
		24V AC/DC	24V AC/DC	24V AC/DC	24V AC/DC	24V AC/DC	24V AC/DC
	MULTIVOLTAGE	100-240V AC	100-240V AC	100-240V AC	100-240V AC	100-240V AC	100-240V AC
WORKING TIME (sec)		8	9	27	27	50	50
TORQUE LIMITER		STD	STD	STD	STD	STD	STD
DUTY RATING		12V AC/DC	50%	50%	50%	50%	50%
		24V AC/DC	75%	75%	75%	75%	75%
		100-240V AC					
PROTECTION (IP rating/UL)		IP68/Type4x	IP68/Type4x	IP68/Type4x	IP68/Type4x	IP68/Type4x	IP68/Type4x
APPROVALS		CE, UL & CSA	CE, UL & CSA	CE, UL & CSA	CE, UL & CSA	CE, UL & CSA	CE, UL & CSA
ENCLOSURE		Aluminum	Aluminum	Aluminum	Aluminum	Aluminum	Aluminum
ROTATION		90°	90°	90°	90°	90°	90°
MECHANICAL STOPS (only reg.0-90°)		NO	NO	STD	STD	STD	STD
MANUAL OVERRIDE		☑ STD 0.39 in	☑ STD 0.39 in	STD with hand wheel and power switch	STD with hand wheel and power switch	STD with hand wheel and power switch	STD with hand wheel and power switch
DOME POSITION INDICATOR		STD	STD	STD	STD	STD	STD
WORKING TEMPERATURE		-4°F + 131°F	-4°F + 131°F	-4°F + 131°F	-4°F + 131°F	-4°F + 131°F	-4°F + 131°F
HEATER		STD	STD	STD	STD	STD	STD
ADDITIONAL LIMIT SWITCHES		n°2 STD (type SPDT)	n°2 STD (type SPDT)	n°2 STD (type SPDT)	n°2 STD (type SPDT)	n°2 STD (type SPDT)	n°2 STD (type SPDT)
ISO 5211 PATTERNS		F03-F05-F07	F05 - F07	F07 - F10	F07 - F10	F07 - F10	F07 - F10
SQUARE DRIVE (mm)		11	14	17	17	22	22
SPECIAL SQUARE DRIVE (mm) UPON REQUEST		9-14	11-17	14-22	14-22	17	17
FAIL-SAFE OPERATION (BATTERY BACKUP)		UPON REQUEST	UPON REQUEST	UPON REQUEST	UPON REQUEST	UPON REQUEST	UPON REQUEST
		NOT AVAILABLE FOR 12V MOD					
STD (4~20mA or 0~10 VDC) REVERSE (20~4mA or 10~0 VDC) MODE POSITIONER		UPON REQUEST	UPON REQUEST	UPON REQUEST	UPON REQUEST	UPON REQUEST	UPON REQUEST
ROTARY POTENTIOMETER (5K Ω 1W)		UPON REQUEST	UPON REQUEST	UPON REQUEST	UPON REQUEST	UPON REQUEST	UPON REQUEST
THREE POSITIONS		UPON REQUEST	UPON REQUEST	UPON REQUEST	UPON REQUEST	UPON REQUEST	UPON REQUEST
ELECTRIC CONDUITS		N°2 1/2" NPT	N°2 1/2" NPT	N°2 1/2" NPT	N°2 1/2" NPT	N°2 1/2" NPT	N°2 1/2" NPT
WEIGHT (Lbs)		7.3	9.9	18.7	18.7	20.9	20.9

POWER CONSUMPTION							
MODEL		VB030M	VB060M	VB110M	VB190M	VB270M	VB350M
VERSION H	NOMINAL VOLTAGE	100-240V AC					
	ABSORBED CURRENT	0.4-0.2 A	0.6-0.3 A	0.4-0.2 A	0.6-0.3 A	0.6-0.3 A	0.75-0.4 A
	ABSORBED POWER	40-48 VA	60-72 VA	40-48 VA	60-72 VA	60-72 VA	75-96 VA
VERSION L	NOMINAL VOLTAGE	12V AC/DC 24V AC/DC	12V AC/DC 24V AC/DC	12V AC/DC 24V AC/DC	12V AC/DC 24V AC/DC	12V AC/DC 24V AC/DC	12V AC/DC 24V AC/DC
	ABSORBED CURRENT	2.2-1.8 A 1-0.7 A	3.8-2.85 A 1.8-1.2 A	2.2-1.8 A 1-0.7 A	3.8-2.85 A 1.8-1.2 A	3.8-2.85 A 1.8-1.2 A	4.75-3.65 A 1.95-1.65 A
	ABSORBED POWER	26.5-22 VA 24-17 VA	46-34 VA 43-29 VA	26.5-22 VA 24-17 VA	46-34 VA 43-29 VA	46-34 VA 43-29 VA	57-44 VA 47-40 VA
FREQUENCY		50/60 HZ					

VB030M – VB060M MOD.

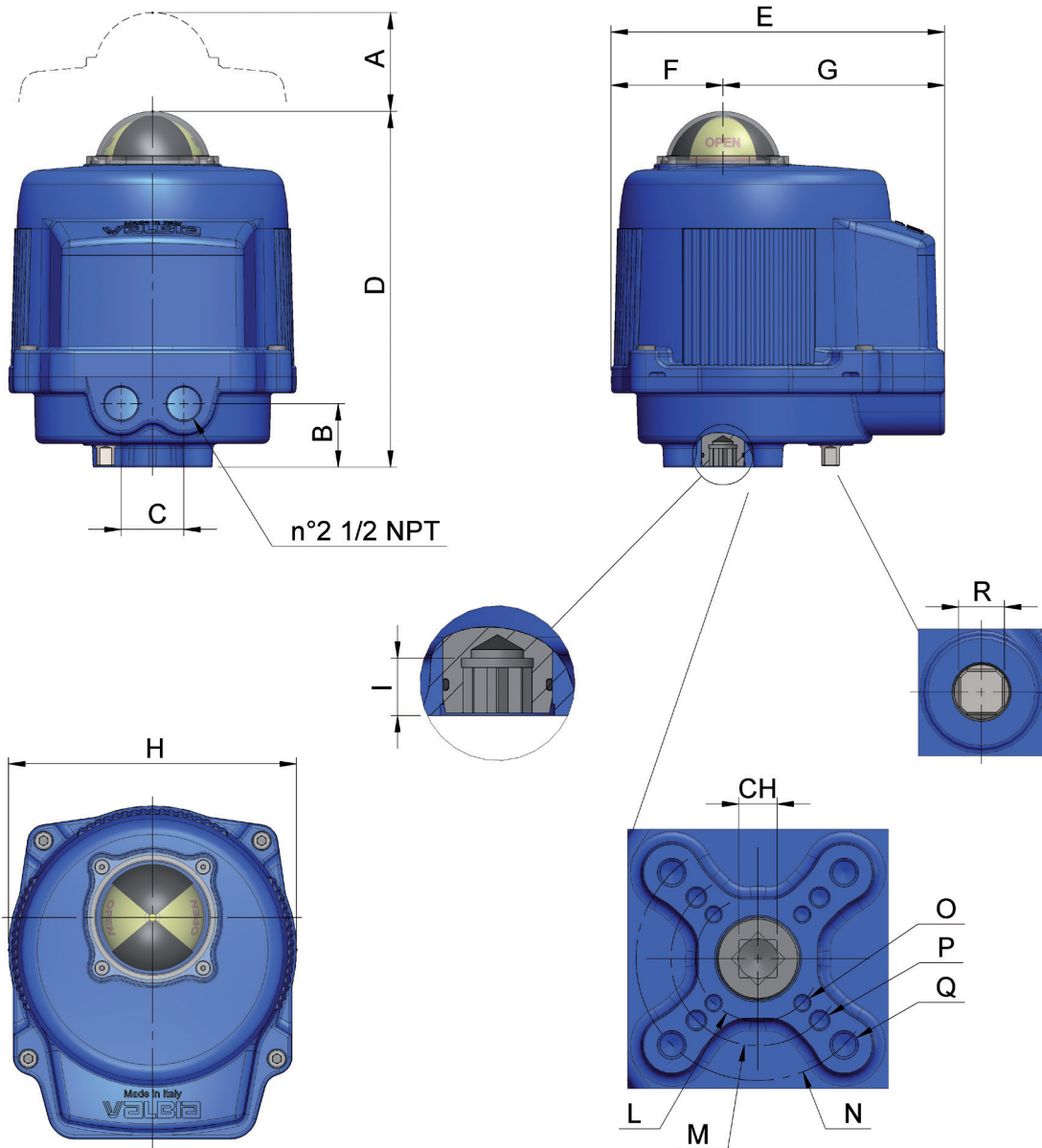

MOD.	ISO 5211 PATTERN	CH mm	A	B	C	D	E	F	G	H	I	L	M	N	O	P	Q	R
VB030M	F03-F05-F07	11	5.47	1.42	1.38	7.83	7.36	2.48	4.88	6.34	0.47	1.42	1.97	2.76	10-24 UNC 2B x 0.31"	1/4-20 UNC 2B x 0.39"	5/16-18 UNC 2B x 0.43"	0.39
VB060M	F05-F07	14	5.47	2.20	1.38	8.66	7.76	2.48	5.28	6.93	0.63	-	1.97	2.76	-	1/4-20 UNC 2B x 0.55"	5/16-18 UNC 2B x 0.59"	0.39

VB110M ÷ VB350M MOD.

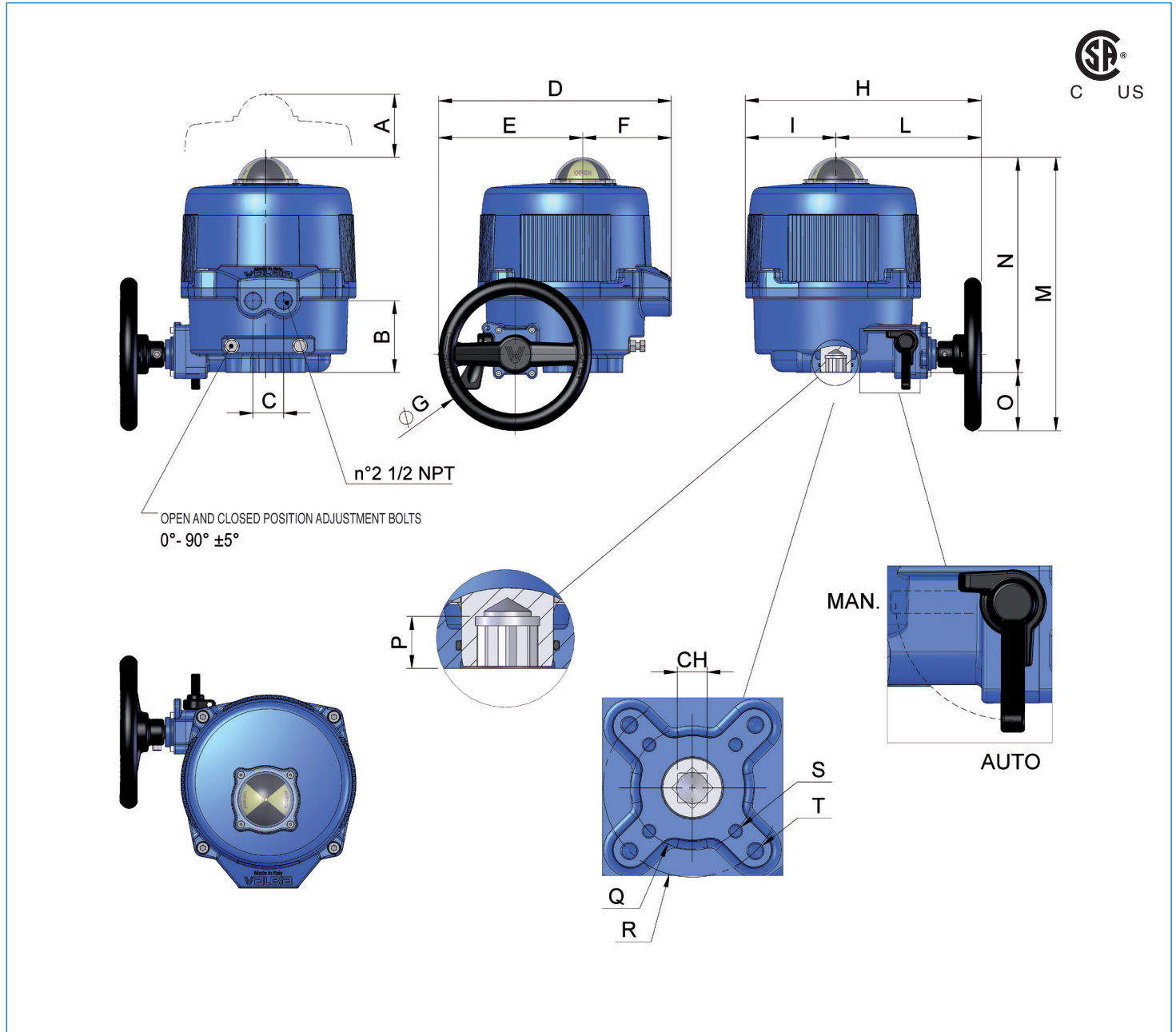

MOD.	ISO 5211 PATTERN	CH mm	A	B	C	D	E	F	G	H	I	L	M	N	O	P	Q	R	S	T
VB110M	F07-F10	17	5.47	3.23	1.38	10.47	6.50	3.98	6.89	10.63	4.05	6.57	12.32	9.68	2.64	0.75	2.76	4.02	5/16-18 UNC 2B x 0.39"	3/8-16 UNC 2B x 0.39"
VB190M	F07-F10	17	5.47	3.23	1.38	10.47	6.50	3.98	6.89	10.63	4.05	6.57	12.32	9.68	2.64	0.75	2.76	4.02	5/16-18 UNC 2B x 0.38"	3/8-16 UNC 2B x 0.38"
VB270M	F07-F10	22	5.47	3.27	1.38	10.98	7.24	3.74	6.89	10.83	4.29	6.53	12.36	9.72	2.64	0.94	2.76	4.02	5/16-18 UNC 2B x 0.59"	3/8-16 UNC 2B x 0.59"
VB350M	F07-F10	22	5.47	3.27	1.38	10.98	7.24	3.74	6.89	10.83	4.29	6.53	12.36	9.72	2.64	0.94	2.76	4.02	5/16-18 UNC 2B x 0.59"	3/8-16 UNC 2B x 0.59"

ELECTRIC WIRING VB010 24V AC/DC 50/60 HZ, 110V AC 60HZ

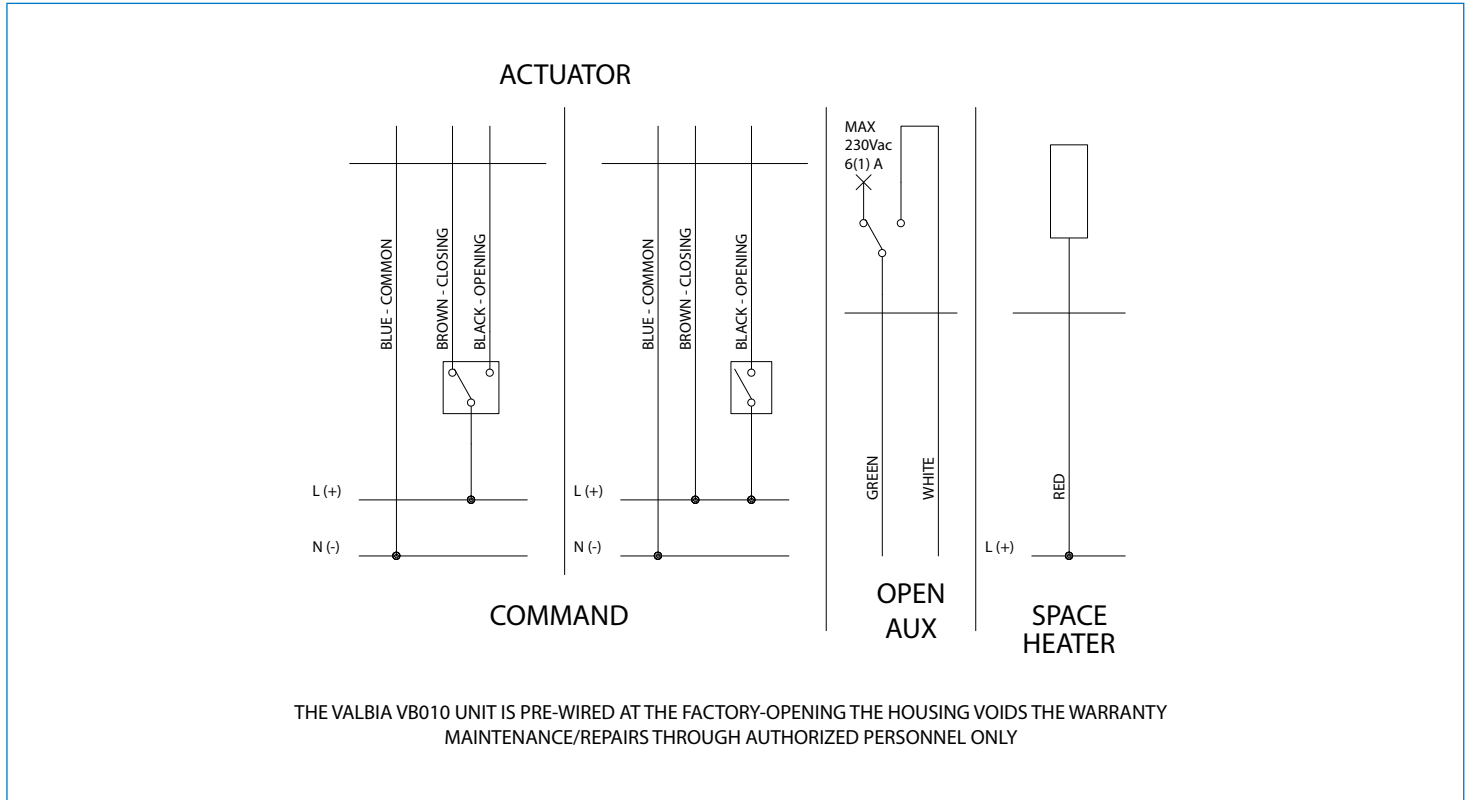

ELECTRIC WIRING VB015 100-240V 50/60Hz

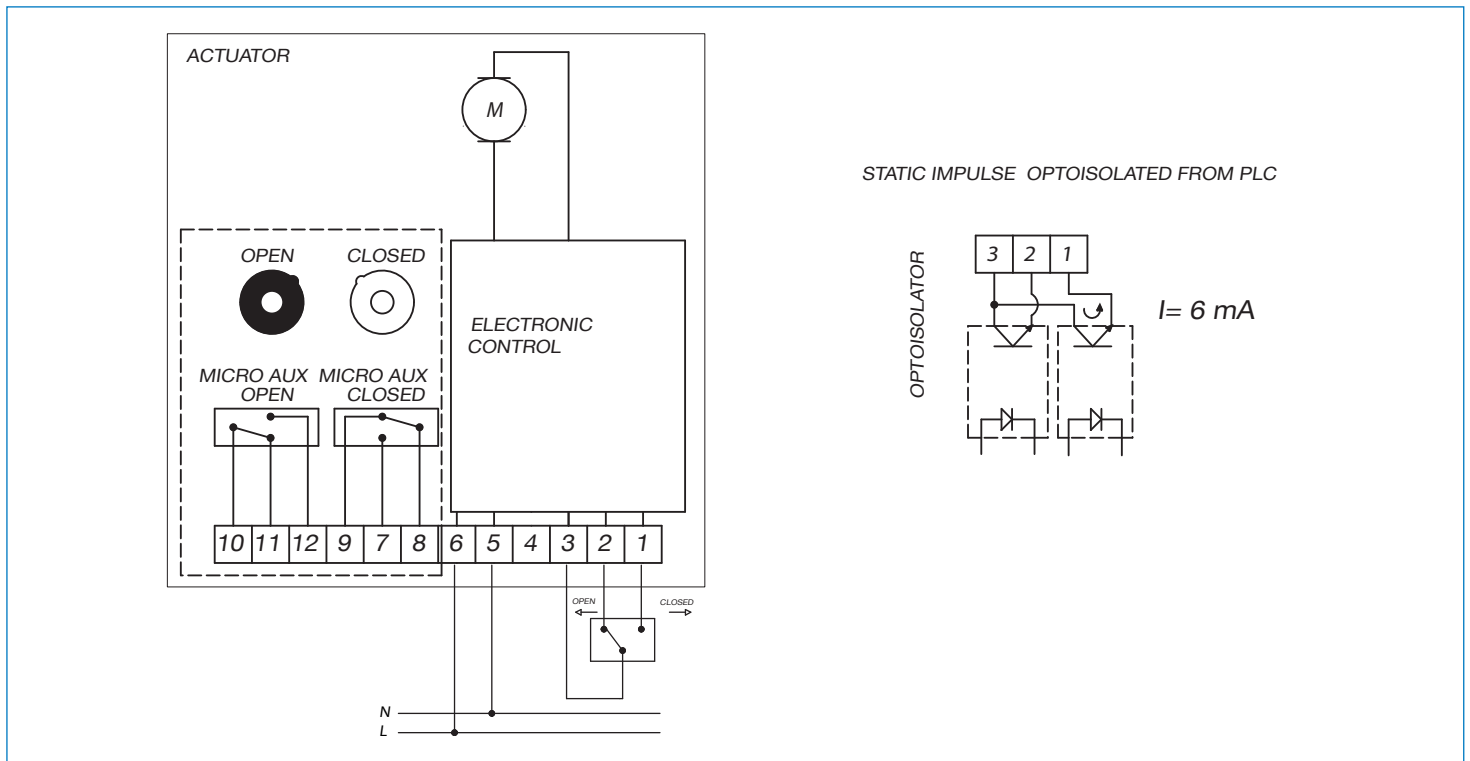

ELECTRIC WIRING VB015 12V-24V AC/DC 50/60 HZ

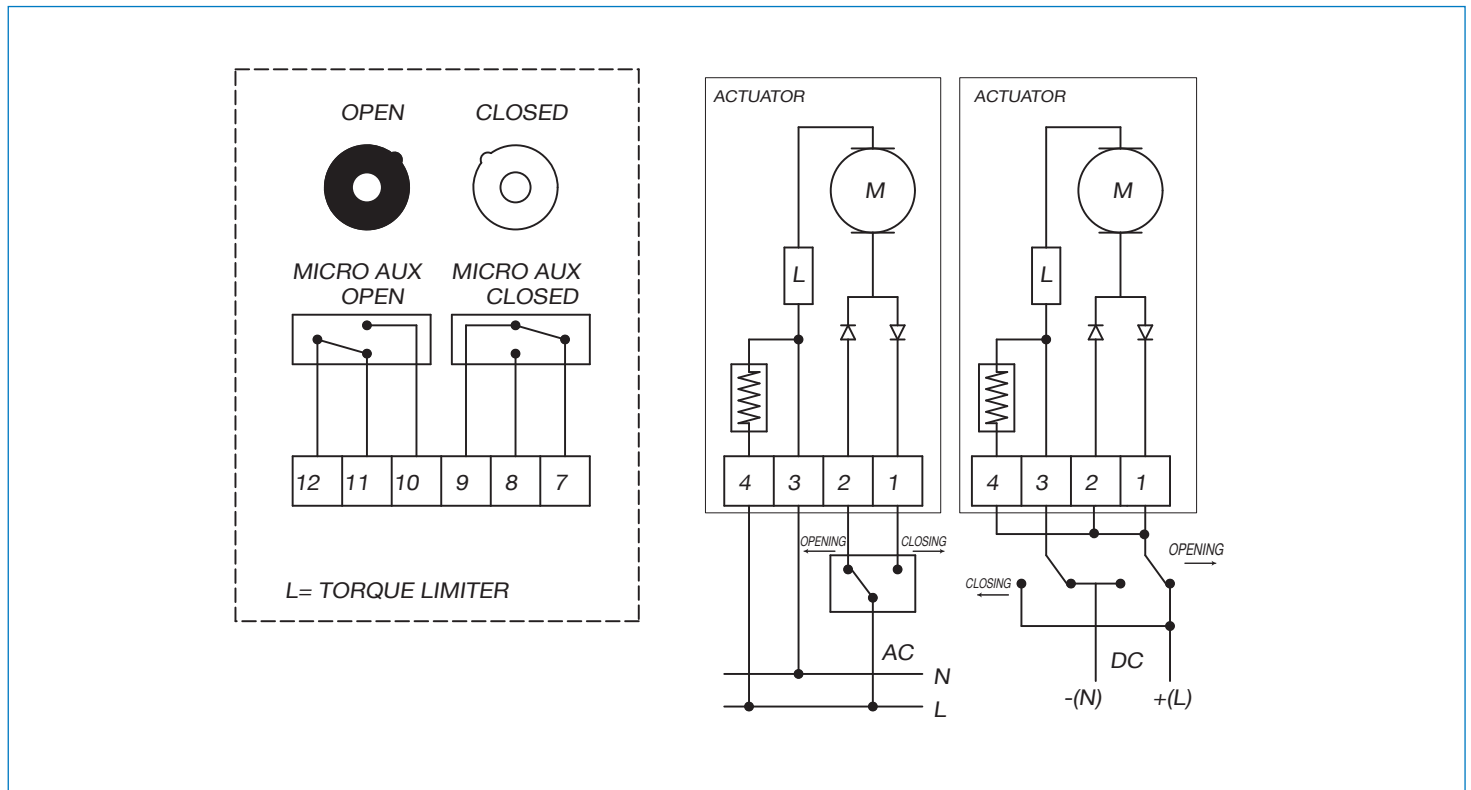

ELECTRIC WIRING FROM VB030 TO VB350 AND FROM VB030M TO VB350M 12V AC/DC 50/60 Hz, 24V AC/DC 50/60 Hz, 100-240V AC 50/60 Hz

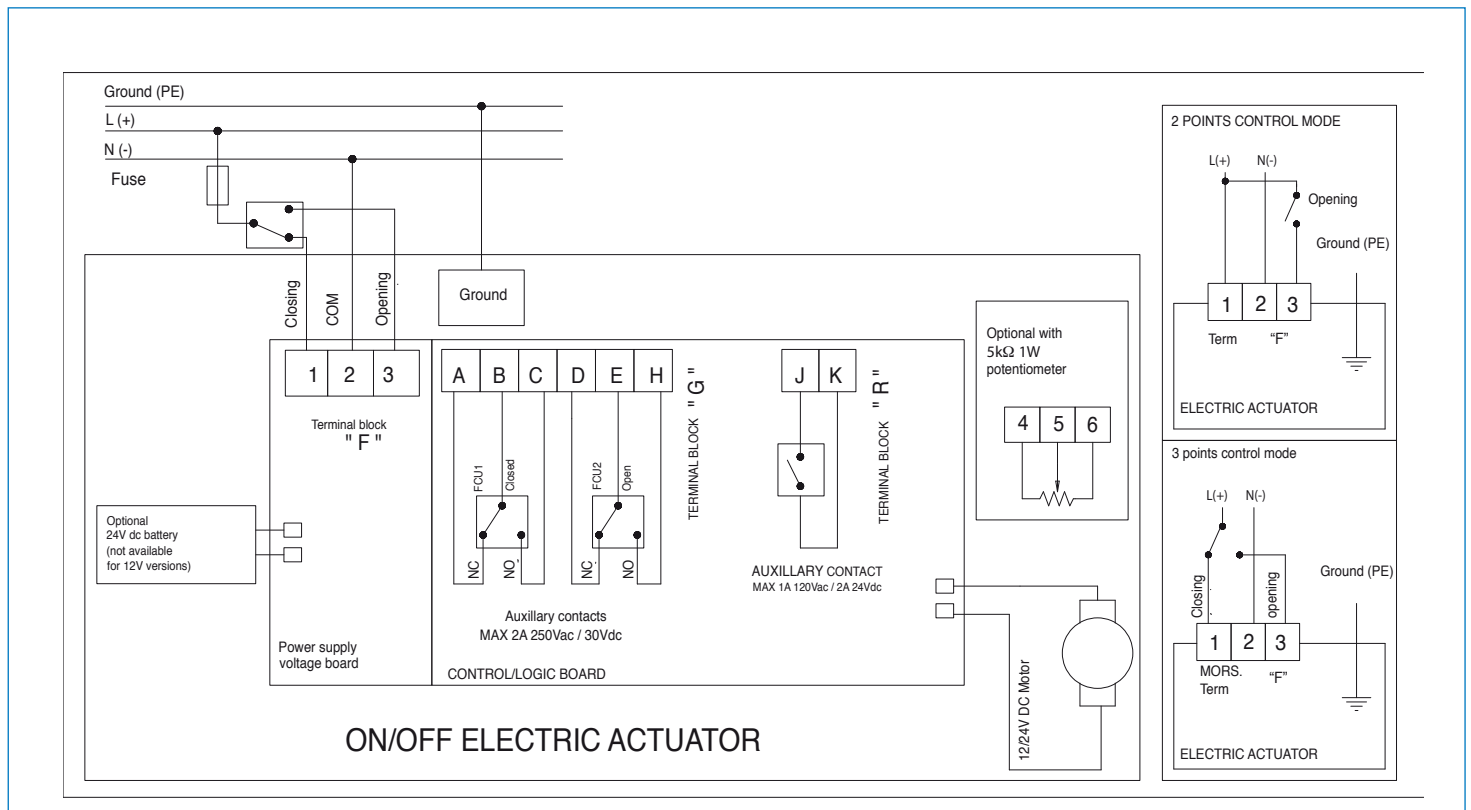

ELECTRIC WIRING WITH POSITIONER FROM VB030 TO VB350 AND FROM VB030M TO VB350M, 24V AC/DC 50/60 Hz, 100-240V AC 50/60 Hz

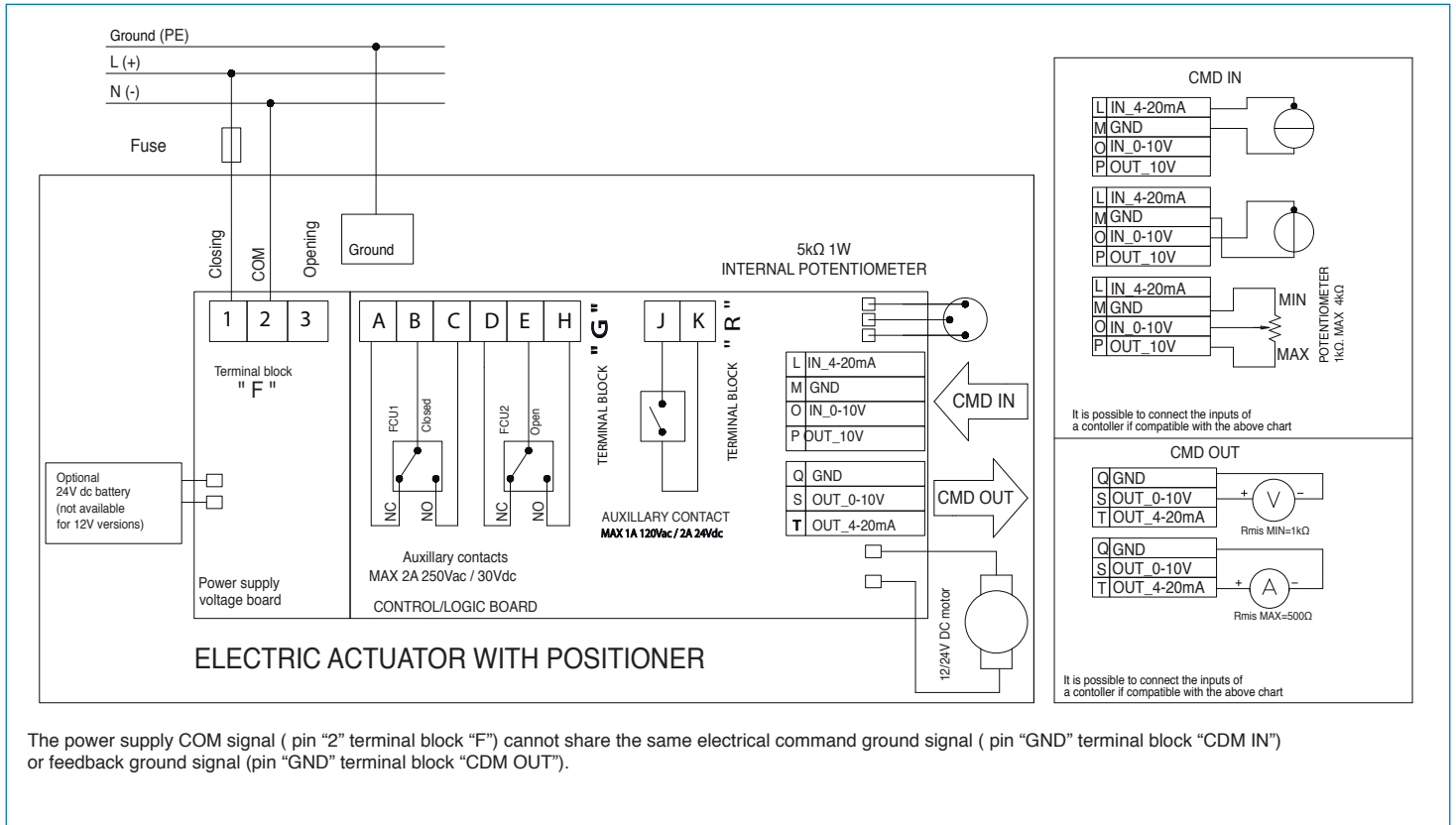

ELECTRIC WIRING WITH THREE POSITIONS FROM VB030 TO VB350 AND FROM VB030M TO VB350M 12V AC/DC 50/60Hz, 24V AC/DC 50/60Hz, 100-240V AC 50/60Hz

